



DuPont™ IntegraTec™ MB PRO 64 H

Modules Installed in Horizontal Pressure Vessels

Key Features

Innovative Multibore™ PRO PES Fibers:

- Exceptional physical strength and chemical resistance.
- High colloidal particulate, bacteria and virus log removal rate.
- Excellent filtration permeability.
- Optional coagulation can enhance the removal of algae and organics.

Optimized Module Design:

- Ideal design to integrate in horizontal pressure vessels.
- Enhanced active filtration area.

Key Applications

- Municipal drinking water.
- Desalination RO pretreatment.
- Designed as a replacement option in alternative UF systems.



Module Specification

General

Part Number / GMID	IN-0124 / 12071523 (includes EP-0115 / 12070222)	
Mode of Filtration	In-Out Pressurized	
Membrane Type	Multibore™ PRO	
Membrane Material	PESm	
Nominal Membrane Pore Size	0.02 μm	
Module Operating Process	Dead-end	
Housing Material	PVC-U, white	

Dimensions

Active Membrane Area	64 m ²	689 ft ²
Module Length	1,537.5 mm	60.5 inch
Module Diameter (D)	220 mm	8.7 inch
Filtrate Collector Inner Diameter (d)	42.6 mm	1.7 inch
Maximum Insertion Depth of Interconnectors	50 mm	2.0 inch

Weight and Volume

Shipping Weight (Module Only)	32 kg	71 lbs.
Weight Empty	32 kg	71 lbs.
Weight Filled	72 kg	159 lbs.
Hold-Up Volume Feed (CIP) ¹	12 L	3.2 gal
Hold-Up Volume Membrane Structure (CIP)	12 L	3.2 gal
Hold-Up Volume Filtrate (CIP)	18 L	4.8 gal

1. Volume applies to the module only (not the total volume of the pressure vessel).



MB PRO



Certified to
NSF/ANSI 61 and 419

powered by



a DuPont brand

Suggested Operating Conditions

General	Details	
Operating Temperature Range	1 - 40 °C	34 - 104 °F
Operating pH	3 - 11	
Cleaning pH	1 - 13	
Typical Filtration TMP	0.1 - 0.6 bar	1.5 - 8.7 psi
Typical Backwash TMP	0.3 - 2.0 bar	4.4 - 29.0 psi
Backwash Flux	230 L/(m ² h)	135 gfd
Backwash Flow	14.7 m ³ h	64.7 gpm
Operating Limits (Maximum)		
Rate of Temperature Change	5 °C/min	9 °F/min
Inlet Pressure (20 - 40 °C)	Please refer to the pressure vessel manufacturer.	
Rate of Pressure Change	0.5 bar/sec	7.3 psi/sec
Filtration TMP	1.5 bar	22 psi
Backwash TMP	3.0 bar	44 psi
Filtration Flux	140 L/(m ² h)	82 gfd
Filtration Flow	8.9 m ³ h	39.2 gpm
Backwash Flux	250 L/(m ² h)	147 gfd
Particle Size	230 µm	
Exposure NaOCl	≤ 250,000 ppm x h (at pH ≥ 9.5)	
Concentration NaOCl	500 ppm	

Horizontal Connecting Kit for DuPont™ IntegraTec™ MB PRO 64 H

Characteristics

Kit Part Number / GMID	EP-0115 / 12070222	
Shipping weight	240 g	8.47 oz

Kit Content	Part number / GMID	Piece
Interconnector Set	EP-0106 / 12070214	1
Spacer Ring	KT-0178 / 12070623	2

Spacer Ring Specifications		
Material	Polypropylene white	
Diameter External (A)	233.4 mm	9.19 inch
Height (B)	46.0 mm	1.81 inch
Weight	70 g	2.47 oz

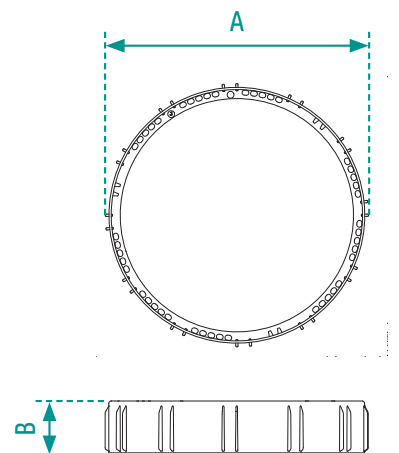

Standard Interconnector Set

Characteristics

Set Content	Piece
Interconnector	1
O-Rings ¹	4

Interconnector Part Number / GMID	EP-0106 / 12070214	
Shipping Weight	100 g	2.81 oz

Specifications

Interconnector		
Material	PVC-U white	
Total Length (L)	109 mm	4.29 inch
Outer Diameter (D)	41.3 mm	1.62 inch
Inner Diameter (d) ²	32.6 mm	1.28 inch
Depth of Insertion into Module (A)	50 mm	1.97 inch
Distance to Outer O-Ring (B)	8 mm	0.32 inch
Width of Stopper (C)	9 mm	0.35 inch
Excess Radius of Stopper (E)	4 mm	0.16 inch

O-Rings		
Material	Peroxide - cured EPDM	
Thickness	4 mm	0.16 inch
Inner Diameter	35 mm	1.38 inch

1. Preassembled on Interconnector.
2. Only valid for Interconnector EP-0106.

Optional Solid Interconnector Set

Depending on pressure vessel configuration, a solid interconnector can be ordered.

Characteristics

Set Content	Piece
Interconnector	1
O-Rings	4

Interconnector Part Number / GMID	EP-0106 / 12070214	
Shipping Weight	210 g	7.41 oz

All other specifications are identical with the Standard Interconnector.

Standard Interconnector Set

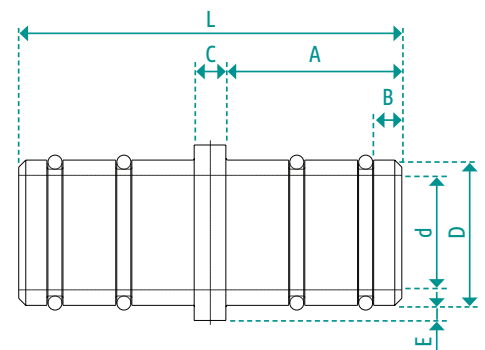
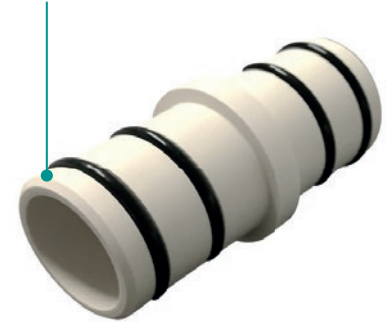

Solid Interconnector Set

General Information

- Avoid any abrupt pressure variations during start-up, operation, shutdown, cleaning or other sequences to prevent possible membrane damage. The maximum pressure change allowable is 0.5 bar/s.
- For assembly please refer to the [DuPont™ IntegraTec™ Pressurized UF In-Out I Series Assembly Manual](#) (Form No. 45-D02563-en).
- If operating limits and guidelines given in this bulletin are not strictly followed, any warranty will be null and void.
- To control biological growth during extended system shutdowns, a storage solution must be introduced into the membrane modules. Detailed information is given in the [DuPont™ IntegraTec™ Pressurized UF Out-In Module Preservation Instruction Manual](#) (Form No. 45-D02946-en).

Regulatory Note

- Certified drinking water modules require specific conditioning procedures prior to producing potable water. For operating parameters, please refer to the [DuPont™ IntegraTec™ Pressurized UF In-Out I Series Process Requirements for Horizontal Modules](#) (Form No. 45-D02233-en).
- Drinking water modules may be subjected to additional regulatory restrictions in some countries. Please check local regulatory guidelines and application status before use.
- Flushing needs to be done according to the [DuPont™ IntegraTec™ Pressurized UF Out-In Module Rinsing Procedure](#) (Form No. 45-D02947-en).



Have a question? Contact us at:
[dupont.com/water/contact-us](https://www.dupont.com/water/contact-us)

All information set forth herein is for informational purposes only. This information is general information and may differ from that based on actual conditions. Customer is responsible for determining whether products and the information in this document are appropriate for Customer's use and for ensuring that Customer's workplace and disposal practices are in compliance with applicable laws and other government enactments. The product shown in this literature may not be available for sale and/or available in all geographies where DuPont is represented. The claims made may not have been approved for use in all countries. Please note that physical properties may vary depending on certain conditions and while operating conditions stated in this document are intended to lengthen product lifespan and/or improve product performance, it will ultimately depend on actual circumstances and is in no event a guarantee of achieving any specific results. DUPONT ASSUMES NO OBLIGATION OR LIABILITY FOR THE INFORMATION IN THIS DOCUMENT. References to "DuPont" or the "Company" mean the DuPont legal entity selling the products to Customer unless otherwise expressly noted. NO WARRANTIES ARE GIVEN; ALL IMPLIED WARRANTIES OF MERCHANTABILITY OR FITNESS FOR A PARTICULAR PURPOSE ARE EXPRESSLY EXCLUDED. No freedom from infringement of any patent or trademark owned by DuPont or others is to be inferred.

DuPont™, the DuPont Oval Logo, and all trademarks and service marks denoted with ™, SM or ® are owned by affiliates of DuPont de Nemours Inc. unless otherwise noted. © 2024 DuPont. All rights reserved.

Form No. 45-D04345-en, Rev. 3
February 2024