

**Water Solutions**

---

# DuPont™ IntegraTec™ P Series PES-UF Modules T-Rack™ and Modules for Open Platform **Process and Design Manual**

**Version 6**

**November 2022**



**NOTICE:** The information provided in this literature is given in good faith for informational purposes only. DuPont assumes no obligation or liability for the information presented herein. NO WARRANTIES ARE GIVEN; ALL IMPLIED WARRANTIES OF MERCHANTABILITY OR FITNESS FOR A PARTICULAR PURPOSE ARE EXPRESSLY EXCLUDED

Powered by



## Table of Contents

|           |  |           |
|-----------|--|-----------|
| <b>1</b>  | <b>Legal Notice .....</b>                                  | <b>4</b>  |
| 1.1       | Product .....  | 4         |
| 1.2       | Change Policy .....  | 4         |
| <b>2</b>  | <b>About these Process and Design Guidelines .....</b>     | <b>5</b>  |
| 2.1       | Objective of these Process and Design Guidelines .....     | 5         |
| 2.2       | Target Groups .....  | 6         |
| 2.3       | Symbols in this Process and Design Guidelines .....        | 6         |
| 2.3.1     | Symbols .....  | 6         |
| 2.3.2     | Notes on Instructions and Rules .....                      | 6         |
| <b>3</b>  | <b>DuPont™ PES In-Out Membranes .....</b>                  | <b>7</b>  |
| <b>4</b>  | <b>Membrane Operating Modes .....</b>                      | <b>9</b>  |
| 4.1       | Filtration .....   | 9         |
| 4.2       | Backwash .....   | 11        |
| 4.3       | Forward Flush .....  | 13        |
| 4.4       | Operating Cycles .....                                     | 15        |
| 4.4.1     | Alternating Operation .....                                | 15        |
| 4.4.2     | Single Sided Operation .....                               | 16        |
| <b>5</b>  | <b>Feed Water Quality and Pretreatment .....</b>           | <b>18</b> |
| 5.1       | Maximum Feed Concentration and Goals of Pretreatment ..... | 18        |
| 5.2       | Microflocculation .....                                    | 19        |
| 5.3       | Performing Microflocculation .....                         | 20        |
| 5.4       | Continuous Chlorination in UF feed water .....             | 23        |
| <b>6</b>  | <b>Chemically Enhanced Backwash (CEB) .....</b>            | <b>24</b> |
| 6.1       | General Overview .....                                     | 24        |
| 6.2       | Types of CEB .....   | 25        |
| 6.3       | How a CEB is Performed .....                               | 26        |
| <b>7</b>  | <b>Chemical Clean-In-Place (CIP) .....</b>                 | <b>28</b> |
| 7.1       | General Overview .....                                     | 28        |
| 7.2       | Establishing CIP Recirculation .....                       | 30        |
| 7.3       | How a CIP is Performed .....                               | 31        |
| 7.3.1     | Preparing the Chemical Solution for a CIP .....            | 31        |
| 7.3.2     | Preparing for a CIP Process .....                          | 31        |
| 7.3.3     | Recirculation and Soaking time .....                       | 32        |
| 7.4       | Preparing to Rinse out the Rack/System .....               | 33        |
| 7.5       | Rinsing out the Rack/System .....                          | 34        |
| <b>8</b>  | <b>Using Chemicals for CEB/CIP .....</b>                   | <b>36</b> |
| 8.1       | Differences between CIP und CEB .....                      | 36        |
| 8.2       | Permissible Chemicals and Operating Conditions .....       | 36        |
| <b>9</b>  | <b>Design and Construction .....</b>                       | <b>40</b> |
| <b>10</b> | <b>System Commissioning .....</b>                          | <b>47</b> |
| 10.1      | General Overview .....                                     | 47        |
| 10.2      | Functional Testing .....                                   | 48        |
| 10.3      | Module Preservation .....                                  | 49        |
| 10.4      | Venting and Rinsing .....                                  | 49        |
| 10.4.1    | Venting the System .....                                   | 49        |
| 10.4.2    | Rinsing the System .....                                   | 50        |

|           |   |           |
|-----------|---|-----------|
| <b>11</b> | <b>Disinfecting the System</b>  | <b>51</b> |
| <b>12</b> | <b>Integrity Testing</b>  | <b>52</b> |
| 12.1      | General Overview  | 52        |
| 12.2      | Compressed Air Specification  | 53        |
| 12.3      | Testing Frequency   | 54        |
| 12.4      | How to Perform a Pressure Hold Test                                   | 54        |
| <b>13</b> | <b>Further Operating Guidelines</b>                                   | <b>58</b> |
| 13.1      | Avoiding Membrane-Damaging Particles and Substances                   | 58        |
| 13.2      | Preventing Chemically Irreversible Fouling                            | 59        |
| 13.3      | Permitted Conditions of Operation, Rinsing, Cleaning and Disinfection | 60        |
| <b>14</b> | <b>System Shutdowns</b>   | <b>62</b> |
| <b>15</b> | <b>Documentation of Operating Conditions</b>                          | <b>63</b> |
| <b>16</b> | <b>Technical Documentation</b>  | <b>64</b> |
| 16.1      | Other Applicable Documents  | 64        |
|           | <b>How to Contact us</b>  | <b>64</b> |

# 1 Legal Notice

## 1.1 Product

This manual applies to DuPont™ IntegraTec™ Series P Pressurized-UF In-Out T-Rack™/ T-Rack™ Modules and PES-UF Modules for Open Platforms, parts and components for installation, assembly and disassembly.

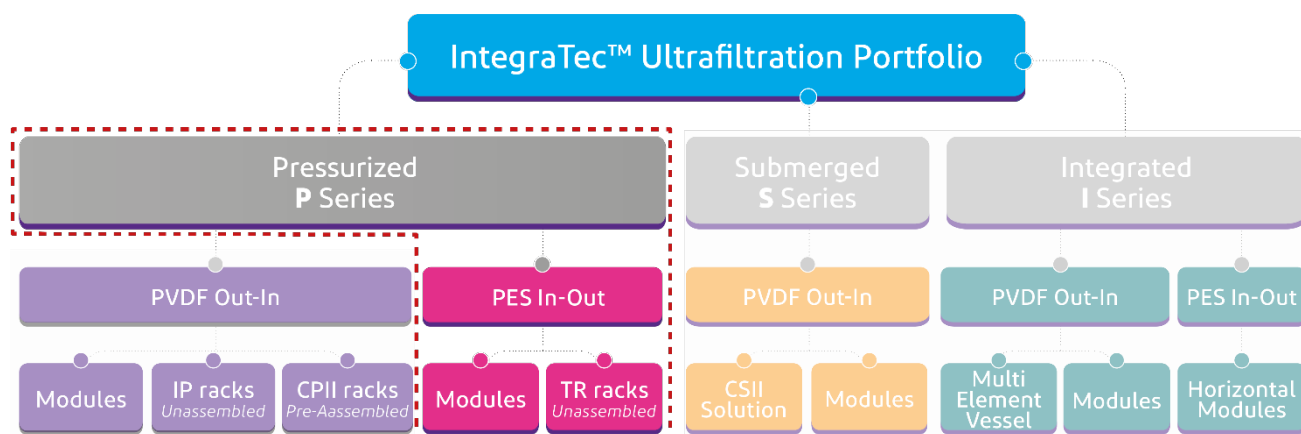

Duplication and archiving in any form whatsoever – including of excerpts – is only permitted with the written consent of the manufacturer.

All brand and company names in these process and design guidelines are registered trademarks of the corresponding companies.

## 1.2 Change Policy

The manufacturer reserves the right to change this process and design guidelines or any part thereof at any time in the interest of continuous product improvement.

The company/party responsible for process and design of the system described in this manual should obtain the current DuPont™ IntegraTec™ pressurized UF In-Out P Series Process & Design Guidelines at regular intervals:

- Download at: <https://www.dupont.com/brands/integrathec-ultrafiltration.html>
- By e-mail to [inge@dupont.com](mailto:inge@dupont.com)
- By telephone under +49 8192 997-700



## 2 About these Process and Design Guidelines

| <b>NOTE</b>   |   |
|---|---|
|  | <p><b>READ THE PROCESS AND DESIGN GUIDELINES!</b></p> <p>Read this document to plan your system.</p> <p>The process and design guidelines described in this document are only to be viewed as recommendations for your system.</p> <p>The system integrator and the operator are responsible for compliance with applicable legal and local regulations for environment, health and safety (EHS).</p> |

### 2.1 Objective of these Process and Design Guidelines

This document contains a detailed description of all process and design guidelines of the DuPont™ IntegraTec™ Series P PES-UF In-Out T-Rack™/ T-Rack™ Modules and PES-UF Modules for Open Platforms.

This document contains instructions and rules for the correct, safe and fault-free design and operation of the system.

#### Warranty Policy

| <b>NOTE</b>   |  |
|---|--|
|  | <p><b>ADHERENCE TO ALL INSTRUCTIONS!</b></p> <p>Full and proper compliance with the instructions in these process and design guidelines is a prerequisite for making a claim under the warranty.</p> <p>Any translations of this document into languages other than English provided to you by DuPont are not official translations and are intended solely as a convenience for non-English reading recipients. The only DuPont-approved and valid version of this document is the most current English version provided by DuPont at the time of sale.</p> <p>In the event of making a warranty claim, the customer agrees to automatically provide DuPont™ with a complete set of documentation.</p> <p>Please contact DuPont™ if you wish to deviate from any of the guidelines or specifications provided in this document and request written approval in advance. Otherwise, you risk invalidating any warranty claims that you may make in the future.</p> |

## 2.2 Target Groups



### Qualified Personnel

- Project and planning engineers/technicians
- Programmers
- Commissioning engineers/technicians
- Design engineers

## 2.3 Symbols in this Process and Design Guidelines

### 2.3.1 Symbols

The following symbols are used in this document:

| <b>SYMBOL</b>   | <b>DESCRIPTION (EXAMPLES)</b>   |
|---|---|
|   | <b>IMPORTANT NOTE!</b><br>Failure to follow the instructions in this note may lead to problems with operating the product.                              |
|  | <b>INFORMATION!</b><br>Following the information provided in this note will simplify commissioning and operation of the pressurized UF In-Out products. |
|  | <b>CROSS REFERENCE!</b><br>Detailed information on this topic can be found in other documentation.  |

### 2.3.2 Notes on Instructions and Rules

To ensure correct, safe and fault-free operation of the system, the document highlights instructions and rules in the following manner:

| <b>NOTE</b>   |  |
|---|--|
|  | <b>ATTENTION!</b><br>Observe the following guidelines! |

### 3 DuPont™ PES In-Out Membranes

DuPont™ PES In-Out membranes feature membranes of the Multibore™ family that combine multiple capillaries of the same diameter into a single fiber with the choice of different capillary arrangements (see Figure 3.1-1):

- Multibore™ with 7 capillaries per fiber
- Multibore™ PRO with 19 capillaries per fiber

Combining multiple capillaries per fiber provides significantly higher mechanical stability compared to conventional single bore hollow fiber membranes.

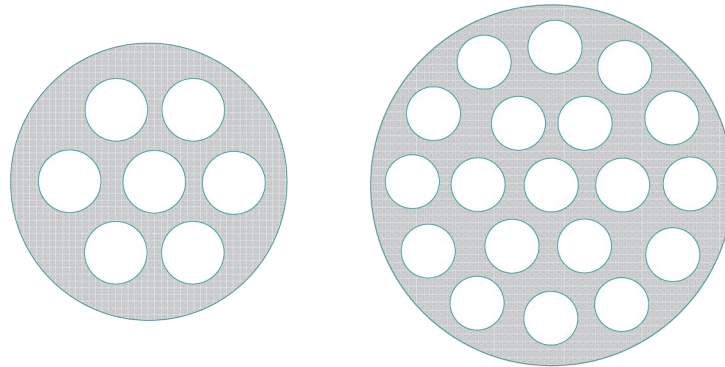

*Figure 3.1-1 Cross-section of DuPont™ PES In-Out Membranes in Multibore™ (left) and Multibore™ PRO (right) capillary arrangement.*

DuPont™ supplies Multibore™ and Multibore™ PRO membranes in different capillary diameters tailored to the type of application.

| <b>0.7 mm<br/>(0.027 inch)</b>            | <b>0.9 mm<br/>(0.035 inch)</b>  | <b>1.5 mm<br/>(0.059 inch)</b>                  |
|---|---|---|
| Most compact for highest footprint saving | Largest range of applications and operation in high TSS water content | Highest tolerance for extreme TSS water content |

DuPont™ PES In-Out membranes are typically operated in dead-end mode and are backwashed at regular intervals. Crossflow operation at low velocities is also feasible in principle, though it is only used in certain circumstances. DuPont™ PES In-Out membranes are "spun" in a single production step from just one polymer solution in a patented production process. Spinning the membranes using just one material creates what is known as an "integral" membrane. This is a qualitative benefit in terms of membrane integrity.

The PES based membrane material is modified in a way that boosts the hydrophilicity of the membrane. This increased hydrophilicity reduces the tendency of the membrane surface to adsorb organics, thereby improving operating performance with less membrane fouling. The manufacturing process produces a defined thin filtration surface (interface) on the inside of the capillaries with extremely low resistance to permeation and with inner pores measuring approximately 20 nanometers (see 3.1-2). This pore size is substantially smaller compared to low pressure membranes of most other ultrafiltration membranes on the market. This ensures a virus rejection of more than 4 log units without any pretreatment step like coagulation and in addition a better removal of foulants if used as pretreatment for reverse osmosis plants. In spite of the smaller pores, DuPont™ PES In-Out membranes show a substantially higher permeability because of the higher surface porosity and a thin filtration interface. This is translated into a very energy efficient operation.

The individual capillaries are firmly connected to each other by a homogeneous support structure that has a permeability some 1,000 times higher than that of the actual filtration interface of the capillaries. The capillaries are spaced at defined distances from each other to ensure a uniform distribution of water for Multibore™ technology-based membranes and superior overall stability.

Smaller pores, lower pressure, the unmatched resistance against high pH cleaning for removing organic foulants and of course the stability are only a few unique characteristics of Multibore™ family membranes.

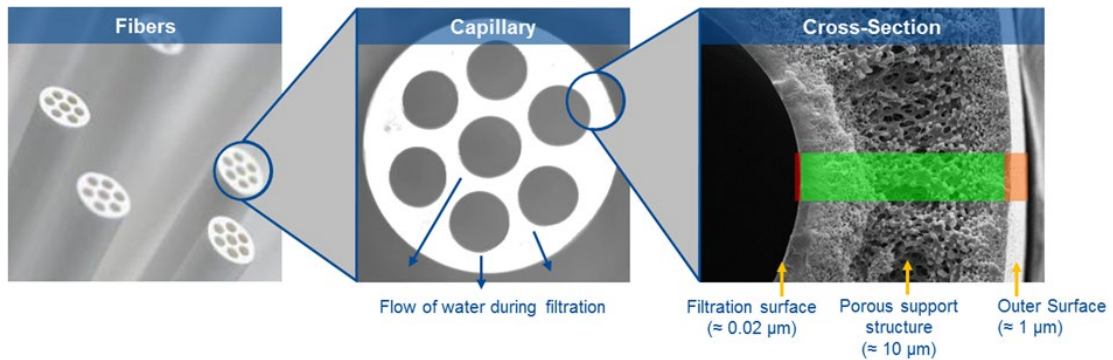

Figure 3.1-2 - Cross-section of a Multibore™ membrane sample

DuPont™ PES In-Out membranes are operated from the inside to the outside of the capillaries in filtration mode and in the reverse direction, i.e. from the outside to the inside of the capillaries, in backwash mode.

DuPont™ PES In-Out membranes reliably remove particles, bacteria and viruses from a variety of water sources, even if fluctuations in the quality of the feed water exist. Maintaining the integrity of the membrane fibers is a key prerequisite for ensuring that contaminants are properly removed from the system. Although capillary defects are extremely unlikely due to the extraordinary stability of membranes from the Multibore™ family, the integrity of the membranes or capillaries can still be affected negatively by factors such as non-approved substances in the feed water and, excessive mechanical stress caused by improper operation.

DuPont™ PES In-Out membranes are encased in a pressure housing. The resulting array is known as the vertical PES-UF Modules, which includes unique design features tailored to the specific requirements of ultrafiltration in the water treatment industry. Particular attention has been paid to optimizing the hydrodynamic characteristics of the internal module design in order to improve backwash efficiency and membrane integrity.



# 4 Membrane Operating Modes

## 4.1 Filtration

In filtration mode, the source water is treated by being forced through the ultrafiltration membrane from the feed side to the filtrate side. The contaminants in the water, which are blocked by the filtration surface, accumulate on the inner surface of the membrane capillaries. The filtrate flows into the filtrate/backwash tank, which serves as a storage container for the backwash water and the water that is to be used for further processing or consumption. Alternatively, the filtrate can be piped directly to the ultimate consumers, in which case the tank is used solely as a storage container for backwash water. The amount of water that can be treated by each UF module depends on a number of factors, including the origin of the water being treated (e.g. ground water, surface water, sea water, or pretreated wastewater), the composition of the source water (e.g. turbidity, concentration of solids, dissolved organics/inorganics, temperature), and the chosen cost strategy (capital cost, operating costs).

The diagrams below show the two operating modes "Filtration Top" and "Filtration Bottom" in dead-end mode. Figure 4.1-1 shows filtration being performed from top (FT) with the source-water being fed into the top of the module, while Figure 4.1-2 shows filtration being performed from bottom (FB) with the source-water being fed into the bottom of the module.

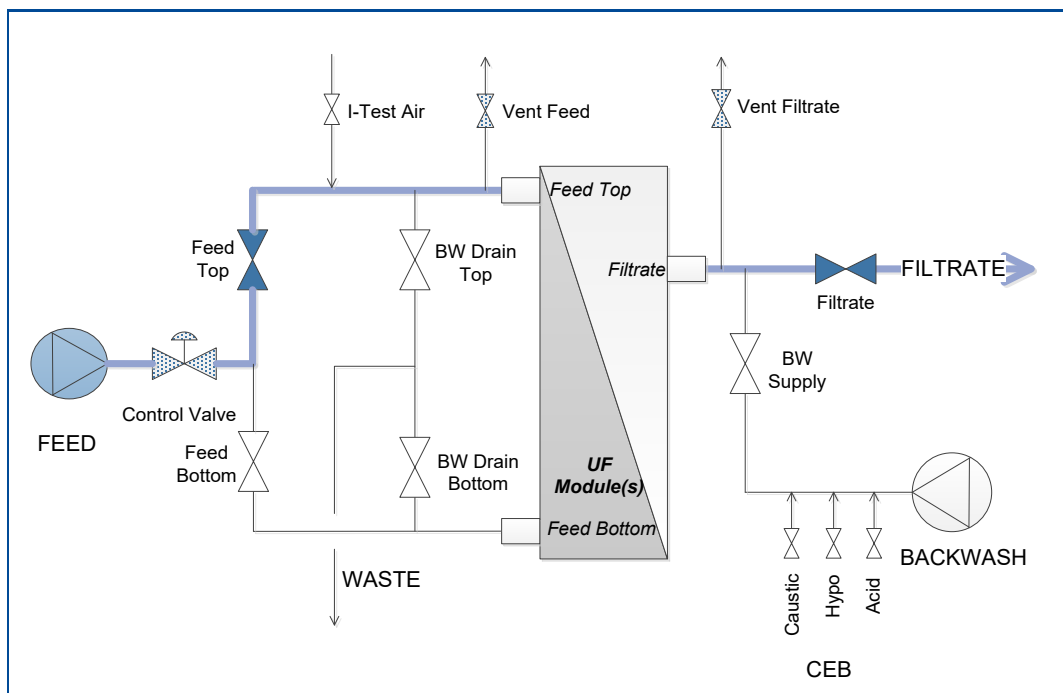

Figure 4.1-1 - Filtration Top (FT) mode

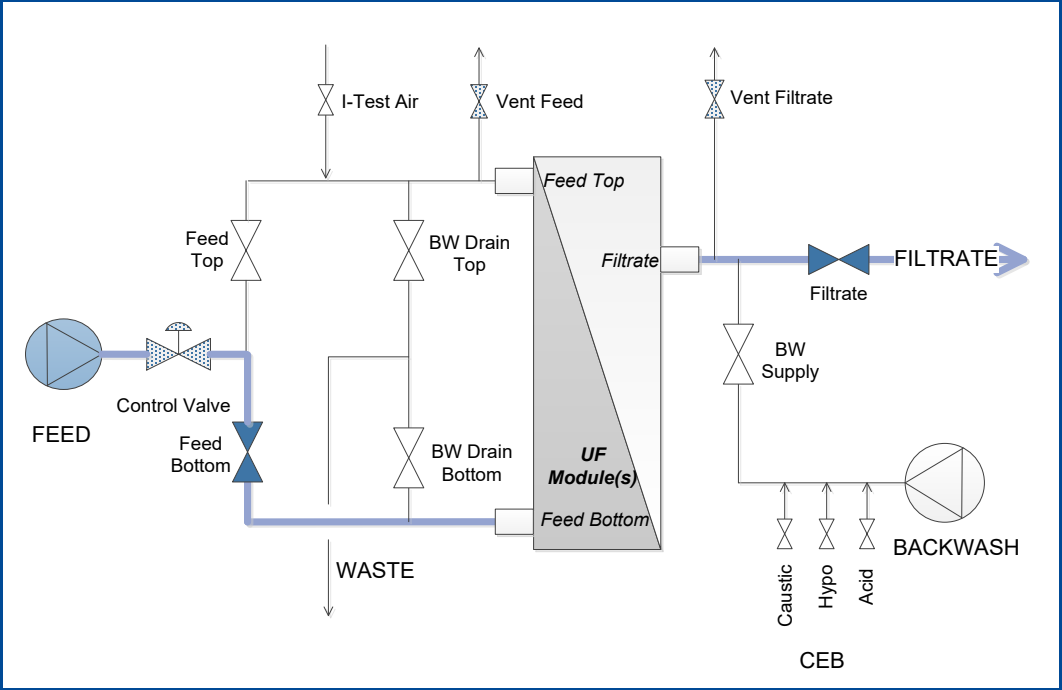



Figure 4.1-2 - Filtration Bottom (FB) mode

## 4.2 Backwash

During the filtration process, the contaminants accumulate on the UF membrane surface and form a filter cake. As a result, the pressure drop required for filtration – also known as the transmembrane pressure (TMP) – increases gradually. In order to remove the filter cake and reduce the TMP, backwashes are performed at regular intervals. The water required for the backwash is drawn from the backwash tank and forced through the module from the filtrate side using the backwash pump. It passes through the membrane from the outside in (i.e. opposite to the direction of flow used in filtration mode) and detaches the accumulated foulant from the membrane surface. The backwash water is then rinsed out of the fiber capillaries and channeled through the module inlet connection to the drain.

| <b>NOTE</b>   |  |
|---|--|
|  | <p><b>ATTENTION!</b><br/>Observe the following guidelines!</p> |

- The backwash water must be free of abrasive or membrane-blocking particles, i.e. the level of water cleanliness must be at least as high as that of PES-UF filtrate. When drawing water from the backwash tank, it is also important to ensure that no corrosion or erosion products that may have formed in the tank or in the pipes are reversed flowed and thus preventing a contamination of UF module(s) filtrate side.
- The recommended backwash flux is 230 l/(m<sup>2</sup>h) (135 GFD). Higher backwash flux rates are applicable up to the limits as described in the respective product data sheets (PDS).

Effective backwash duration varies between 30 and 60 seconds depending on the quality of the feed water, the type of operating cycle and the size of the installation.

- To ensure reliable cleaning even when the membranes are heavily fouled, it is important to maintain a constant flow rate using a flow control system. One way this can be achieved is by using a backwash pump driven by a frequency converter. The frequency converter should be configured to ensure that the designated flux rate l/(m<sup>2</sup>h) is achieved within 5 – 7 seconds or less without pressure surges. The use of slow acting valves is advised to avoid possible water hammers.

**Backwash Operating Modes**

The following diagrams show the two backwash operating modes "Backwash Drain Bottom" and "Backwash Drain Top". Figure 4.2-1 shows a Backwash Drain Bottom (BWDB) in which the backwash water (filtrate) exits the module at the bottom feed/drain port, while Figure 4.2-2 shows a Backwash Drain Top (BWDT) in which the backwash water (filtrate) exits the module at the top feed/drain port.

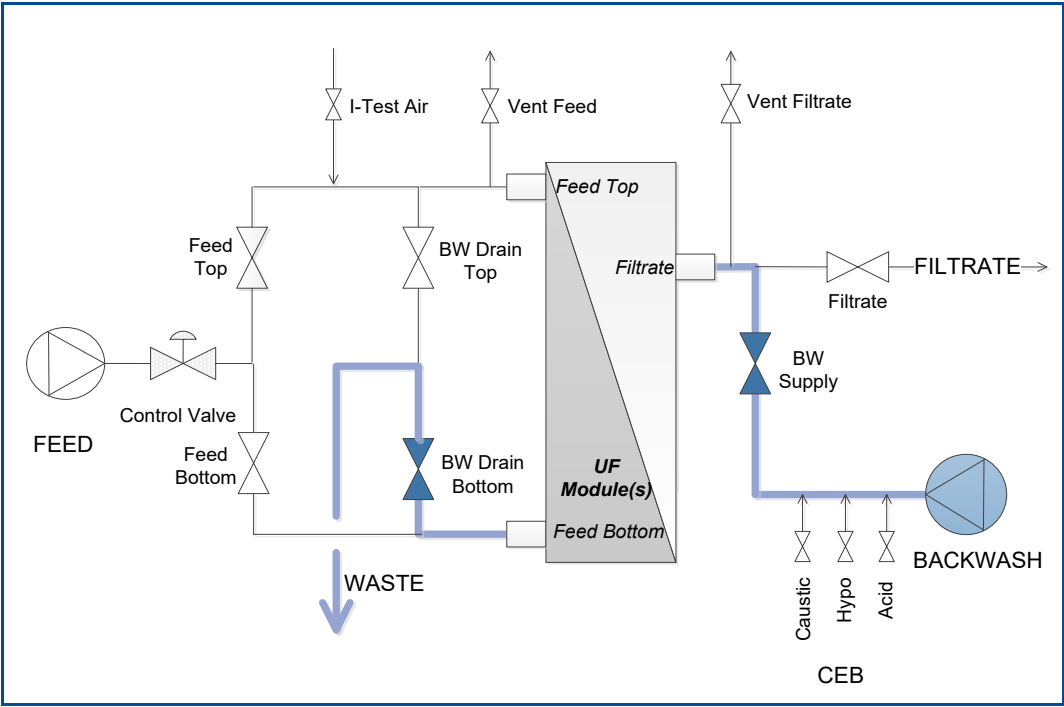

Figure 4.2-1 - Backwash to Drain Bottom (BWDB)

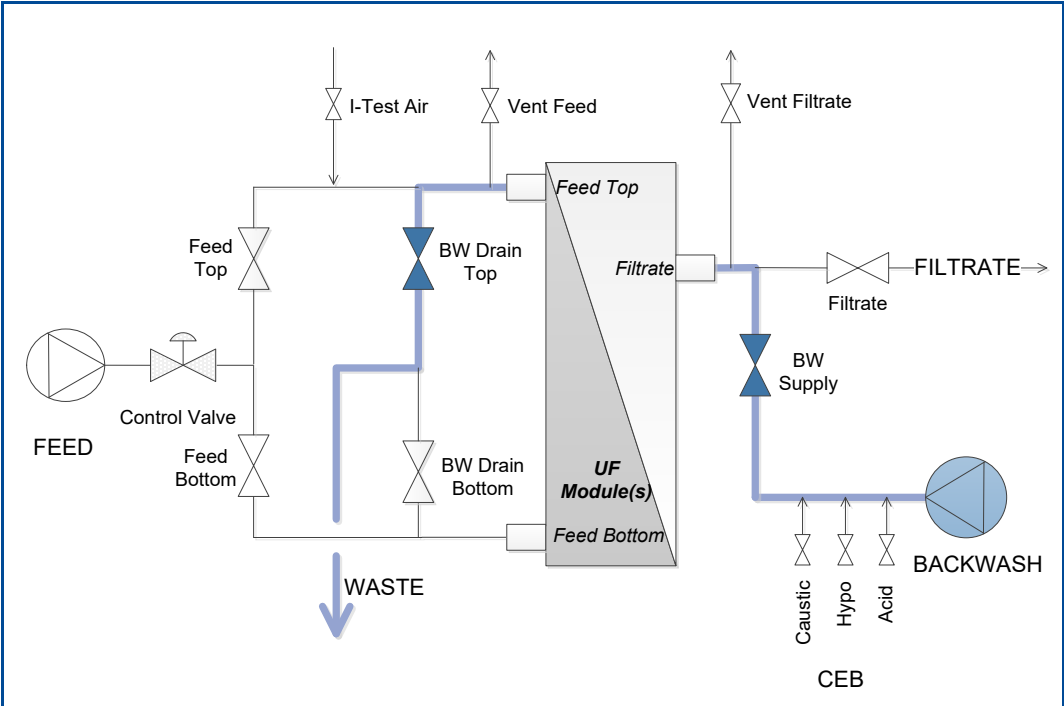

Figure 4.2-2 - Backwash to Drain Top (BWDT)

## 4.3 Forward Flush

When treating source-water with high concentrations of solids, it may be advantageous to perform a forward flush prior to the backwash. A forward flush can also be used to flush solids out of the system which have been loosened from the membrane by a backwash, thereby potentially reducing the quantity of filtrate required for the backwash. A forward flush also serves to ensure that no residues of the preceding backwash can return to the membrane in a subsequent filtration stage. This method can boost cleaning performance while simultaneously improving recovery rates.

Performing a forward flush is optional; if this option is activated, the forward flush will be performed before and/or after a backwash. The forward flush is carried out using the filtration pump at a constant volume flow rate equivalent to the filtration flux rate. For this reason, the volume flow rate for the forward flush is specified here in L/(m<sup>2</sup>h)(GFD). No additional pump is required for the forward flush.

As shown in Figure 4.3-1 and Figure 4.3-2, the drain is kept open, and the filtrate valve is closed during a forward flush. This means that all the water flows lengthwise through the membrane capillaries. This method is particularly effective at removing particulate matter, especially at the end of the membrane capillaries. A forward flush generally occurs between 20 and 40 seconds. It can be performed either top-to-bottom (FFT) or bottom-to-top (FFB).

In most applications a forward flush is not necessary.

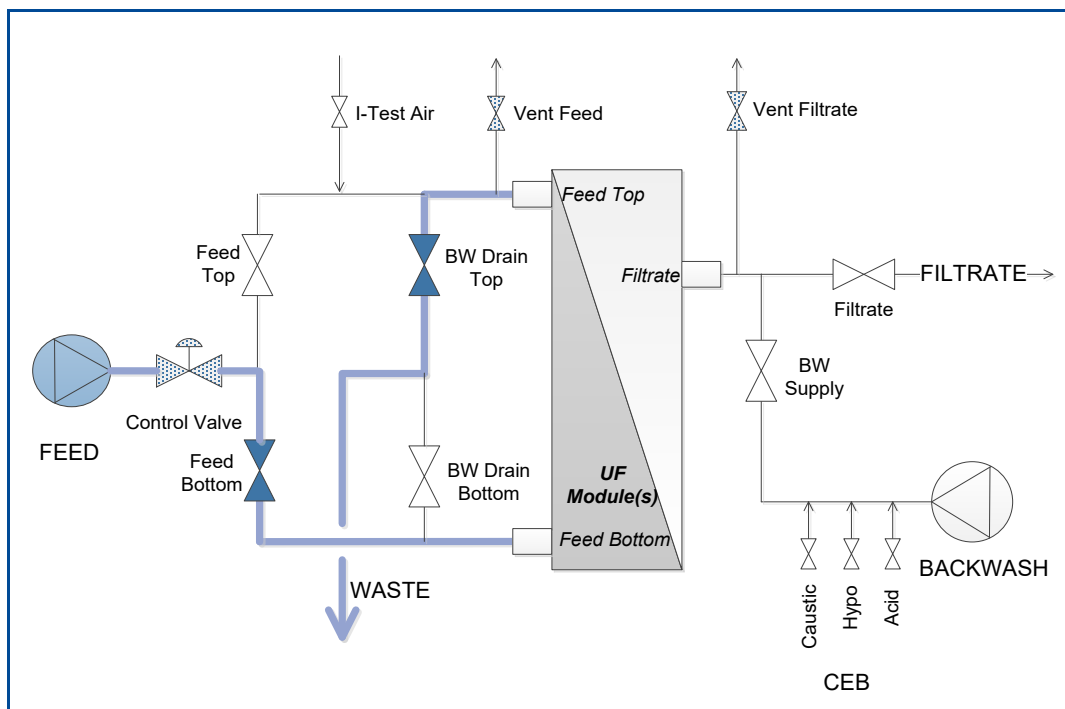

Figure 4.3-1 - Forward Flush Top (FFT)

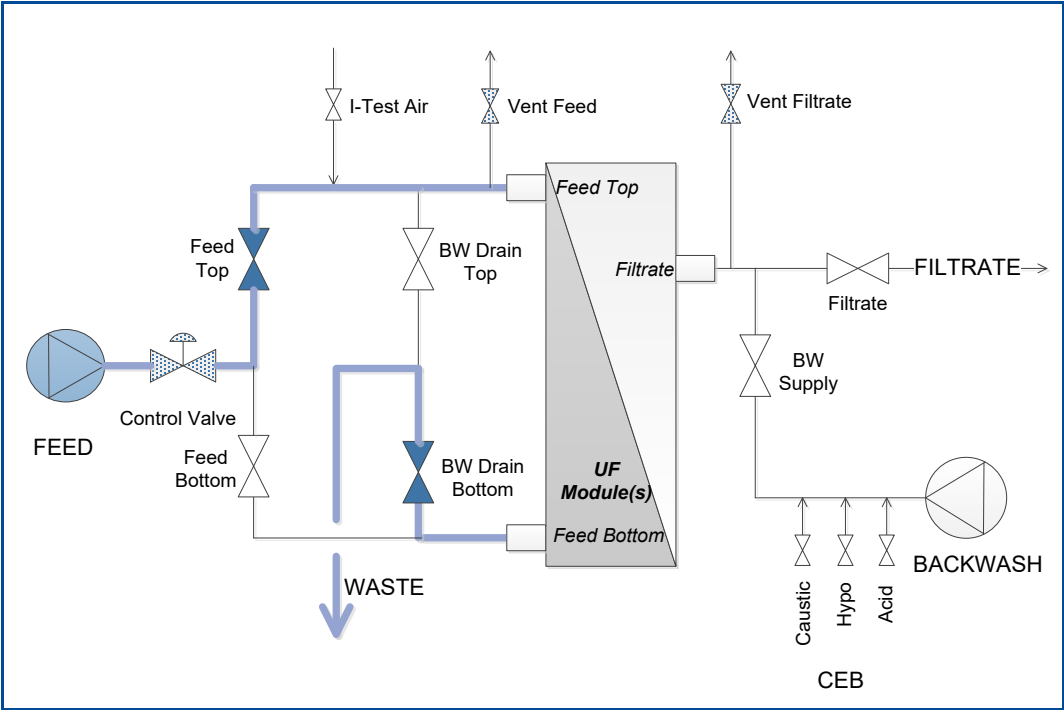

Figure 4.3-2 - Forward Flush Bottom (FFB)

## 4.4 Operating Cycles

In this context, an ultrafiltration operating cycle refers to a sequence of operations comprising a filtration sequence followed by a backwash sequence. It is generally sufficient to run the backwash sequence without a forward flush, in other words, only to do a backwash. The duration of the forward flush should generally be set to 0 second. In certain applications, however, forward flushes may prove necessary either before or after the backwash event. The duration of all operating modes should be user settable to allow for maximum process flexibility.

Based on long-term experience The frequency converter should be configured to ensure that the designated flux rate is achieved within 5 – 7 seconds or less without pressure surges. two main operating philosophies (called alternating operation and single sided operation) are well established.

### 4.4.1 Alternating Operation

The feed fluid is directed into the module(s)/rack(s) from bottom and top inlet ports in an alternating manner as shown in Figure 4.4-1.

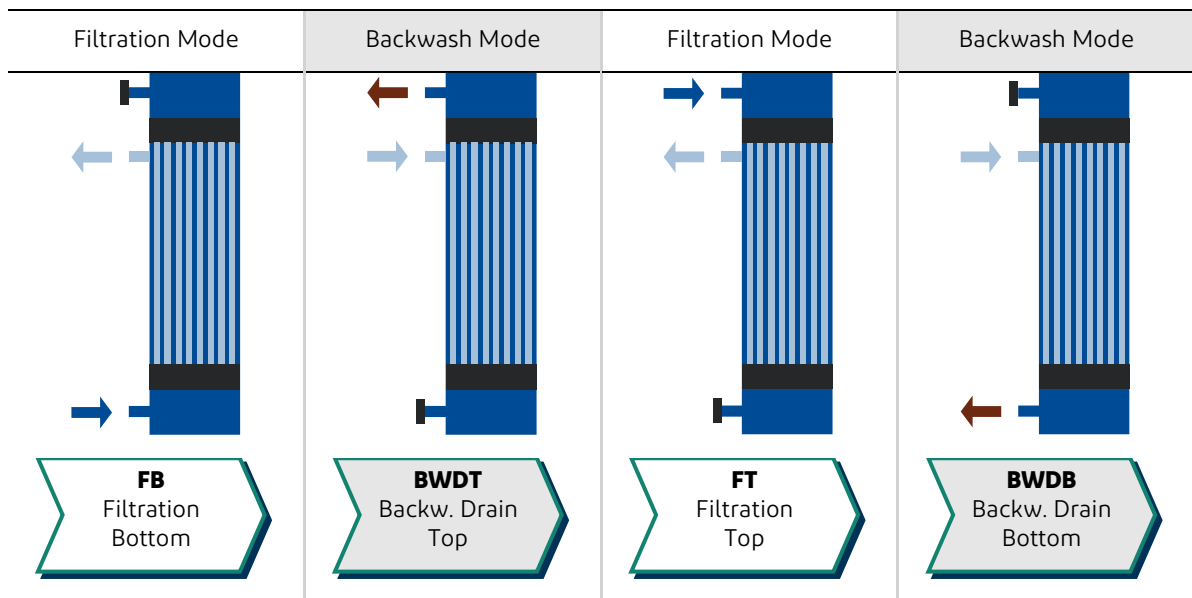

Figure 4.4-1 - Alternating Operation

Filtration bottom (FB) / backwash drain top (BWDT) is followed by filtration top (FT) / backwash drain bottom (BWDB) and so on in a continuous repetition.

4.4.2 Single Sided Operation

Single sided operation is applicable only when T-Rack™ Manifold or other manifold designs with bottom inlet (feed bottom) are used. During single sided operation, the reverse combined backwash (RCBW) process as shown in Figure 4.4-2 must be used.

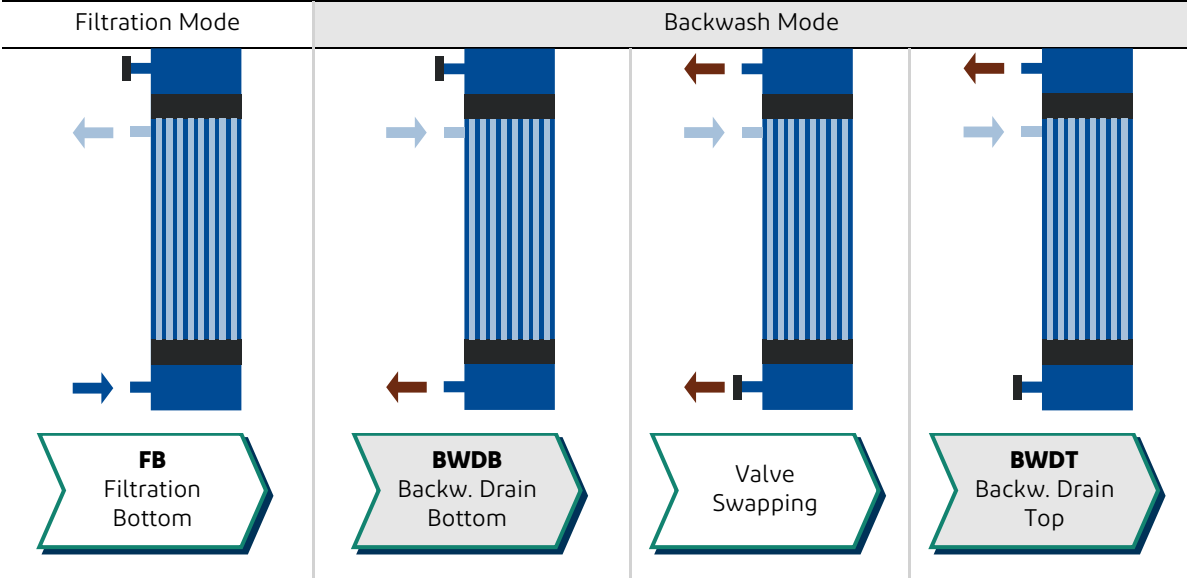



Figure 4.4-2 - Single Sided Operation

Filtration bottom (FB) is followed by a reverse combined backwash (RCBW) sequence (BWDB / VS / BWDT) and so on in a continuous repetition.



| <b>NOTE</b>   |   |
|---|---|
|  | <p><b>ATTENTION!</b></p> <p>Observe the following guidelines!</p> |

- In order to keep the valve swapping time during backwash mode at a minimum (5-10 seconds depending on valve operation time), the valve opening of BWDT side and the valve closing of BWDB are recommended to be released in parallel (= Valve Swapping).
- In the following Figure 4.4-3 please find the PES-UF recommendations for the theoretical RCBW time settings and some practical examples.

| <b>Gross Backwash Time   <math>t_{BW\ Gross}</math></b>   |                          |                                    |  |                        |   |  |                                     |  |  |  |
|---|--------------------------|------------------------------------|--|------------------------|---|--|-------------------------------------|--|--|--|
| Backwash Drain Bottom   |                          | Valve Swapping<br>(valve position) | Backwash Drain Top                                       |                        |   |  |                                     |  |  |  |
| Ramping<br>(up) Time  | BWDB                     | Valve Swapping                     | BWDT   | Ramping (down)<br>Time |   |  |                                     |  |  |  |
| $t_R$   | $t_{BWDB}$               | $t_{Valve\ Swapping}$              | $t_{BWDT}$   | $t_R$                  |   |  |                                     |  |  |  |
| 7 s   | $0.5 \times t_{BW\ Net}$ | 5-10 s                             | $t_{BW\ Net}$<br>- $t_{BWDB}$<br>- $t_{Valve\ Swapping}$ | 7 s                    |   |  |                                     |  |  |  |
| <table border="1" style="margin: auto; border-collapse: collapse; text-align: center;"> <thead> <tr> <th colspan="2" style="background-color: #f2f2f2;"><b>Net Backwash Time   <math>t_{BW\ Net}</math></b></th> </tr> <tr> <th colspan="2">at BW Flux 230 L/(m<sup>2</sup>h)</th> </tr> </thead> <tbody> <tr> <td colspan="2" style="height: 30px;"> </td> </tr> </tbody> </table> |                          |                                    |  |                        | <b>Net Backwash Time   <math>t_{BW\ Net}</math></b> |  | at BW Flux 230 L/(m <sup>2</sup> h) |  |  |  |
| <b>Net Backwash Time   <math>t_{BW\ Net}</math></b>   |                          |                                    |  |                        |   |  |                                     |  |  |  |
| at BW Flux 230 L/(m <sup>2</sup> h)   |                          |                                    |  |                        |   |  |                                     |  |  |  |
|   |                          |                                    |  |                        |   |  |                                     |  |  |  |

*Figure 4.4-3 - Theoretical RCBW time settings and practical examples*

- The functional descriptions, including advice for programming the control logic can be provided on request.

## 5 Feed Water Quality and Pretreatment

### 5.1 Maximum Feed Concentration and Goals of Pretreatment

| <b>NOTE</b>   |  |
|---|--|
|  | <b>ATTENTION!</b><br>Observe the following guidelines! |

- In some situations, the feed water may contain or may be expected to contain substances that could potentially damage the membrane or membrane fibers or that may cause fouling or scaling which would be too complex to remove even with chemical CIP (Clean-In-Place) cleanings. In such cases it is essential to carry out effective pretreatment steps to remove these substances from the water prior to ultrafiltration.
- The presence of predominantly large particles in the feed water may result in irreversible fouling of the capillaries or in damage to the membrane or membrane fibers. Large and/or sharp particles must therefore be removed by an upstream pre-filter.

The quality of the water fed into a membrane system has a major impact on the membrane's performance, recovery and availability. Substances in the water that permanently exceed a critical concentration or temporarily rise above a maximum concentration can cause flux rates, achievable permeability and recovery rates to fall below the stated design values. This also applies to the dosing of inorganic iron or aluminum-based coagulants and powdered activated carbon. Concentrations that exceed permitted levels may also significantly increase the frequency of chemically enhanced backwashes (CEB) required to maintain stable operation as well as the frequency of chemical Clean-In-Place (CIP) to remove stubborn fouling/scaling substances. This could lead to higher chemical consumption and negatively affect system availability.

No fixed values can be given for critical and maximum concentrations of feed water contaminants. Membrane compatibility of many contaminants will differ depending on the type and even the sub-type of the source-water used and the exact nature of the encountered contaminants, such as e.g. the type and quality of the added powdered activated carbon.

## 5.2 Microflocculation

### General Overview

Dissolved Organic Carbon (DOC) in the UF feed water can cause build-up of a hydraulically hard to remove fouling layer as well as contaminate the UF filtrate water due to passage through the UF membranes. Microflocculation is used to prevent or reduce the negative effects of dissolved organic matter by precipitation and ultimately rejection of the organic molecules on the UF membranes. In many ultrafiltration installations, microflocculation by means of inline-coagulation is thus effectively used as a pretreatment process. In contrast to sedimentation and depth filtration, which require the formation of larger macroflocs, ultrafiltration only requires coagulation with subsequent formation of so-called "microflocs". This has the advantage of reducing the required quantity of coagulants and minimizing the quantity of sludge produced.

Depending on the concentration and characteristic structure of the dissolved organics in the feed water, specific quantities of inorganic coagulant (usually metal salts such as  $\text{FeCl}_3$ , or polyaluminum chloride (PACl)) are added to the water prior to ultrafiltration and moderate amounts of energy, in the form of mixing, are then applied to form microflocs. The principal effects are a reduction of free organic contaminants as a result of the binding of the dissolved organics in the iron or aluminum flocs and the formation of a porous coating layer of microflocs on the membrane surface which helps to promote a stable filtration process and high backwash effectiveness and can therefore be used to increase or stabilize the membrane performance.

In addition, proper application of the microflocculation process can improve the filtrate water quality, particularly in regard to the concentration of DOC (which in some cases can be reduced by up to 60%), the SDI (Silt Density Index = clogging index; a key quality parameter for a reverse osmosis system downstream from the UF system), and the phosphate concentration (especially important in Wastewater applications).

When performing microflocculation, it is important to note that the concentration of the residues of dosed metal salts in the filtrate should not exceed 1% of the added metal concentration and should under no circumstances exceed any relevant limits that may apply (e.g. for drinking water treatment).

### 5.3 Performing Microflocculation

The goal of microflocculation (by using inline-coagulation) is to remove as much DOC as possible while simultaneously maintaining process conditions to minimize the amount of coagulant that remains in the UF filtrate. Achieving this goal requires precise adjustment of the inline-coagulation process. Based on the type of coagulant and the quality of the source water, an acid or caustic must be used to adjust the pH value in order to ensure an optimum pH for coagulation and microflocculation. The required contact time for the coagulant depends on the type and concentration of the coagulant, the water chemistry and the water temperature.

In order to define the best possible coagulation parameters, DuPont™ recommends conducting jar tests in a preliminary phase. The coagulant dosing system can then be designed based on the results of these tests. It is important that the jar tests focus on analytical parameters such as residual concentrations of Al and Fe and DOC removal rather than optical parameters such as floc formation. Table 5.3-1 gives an overview of various coagulants and their key characteristics.

*Table 5.3-1 - Inline-Coagulation and microflocculation parameters*

| Coagulant  |         | FeCl <sub>3</sub> | PACI       |
|--|---------|-------------------|------------|
| <b>Dosage of Fe/Al<sup>1</sup></b>                         | [mg/l]  | 0.3 - 7.0         | 0.2 - 5.0  |
| <b>Specific dosing (Me<sup>3+</sup>/DOC)</b>               | [mg/mg] | 0.5 - 2.0         | 0.25 - 0.5 |
| <b>pH range</b>  |         | 5.0 - 10.0        | 6.5 - 7.5  |
| <b>pH Optimum</b>  |         | 6.8 - 7.0         | 6.8 - 7.0  |
| <b>Contact time<sup>2</sup></b>                            | [s]     | 30 - 60           | 30 - 60    |
| <b>DOC elimination rate<sup>3</sup></b>                    | [%]     | 10 - 60           | 10 - 60    |
| <b>Rest quantity (as percentage of dosage)<sup>4</sup></b> |         | 1 %               | 1 %        |

- <sup>1</sup> The dosage can be decreased for swimming pool applications (e.g. 0.03 mg/l AL/Fe).
- <sup>2</sup> Contact time may show significant variation depending on water temperature, pH value, water chemistry and treatment goals (t < 30 seconds and t > 60 seconds) → potential for optimization.
- <sup>3</sup> Removal of organics depending on water chemistry and coagulation parameters (pH value, etc.).
- <sup>4</sup> Significant residues of Me<sup>3+</sup> (metal salts) above natural pre-existing concentration indicate a problem with the coagulation parameters (mixing conditions, pH value, alkalinity, contact time, dosage) and should be strictly avoided.

It is important to note here that using the pre-filter to mix the coagulant may lead to fouling or scaling of the pre-filter (e.g. precipitation of Al hydroxides). Chemicals may then be required to remove this fouling if it can no longer be removed by backwashing alone. DuPont™ therefore recommends installing the pre-filter upstream from the coagulant dosing station or downstream from the contact zone. In the event that the existing piping does not guarantee sufficient contact time, a contact tank can be installed to increase the coagulant contact time. The following process diagrams show a range of different configurations for inline-coagulation and microflocculation.

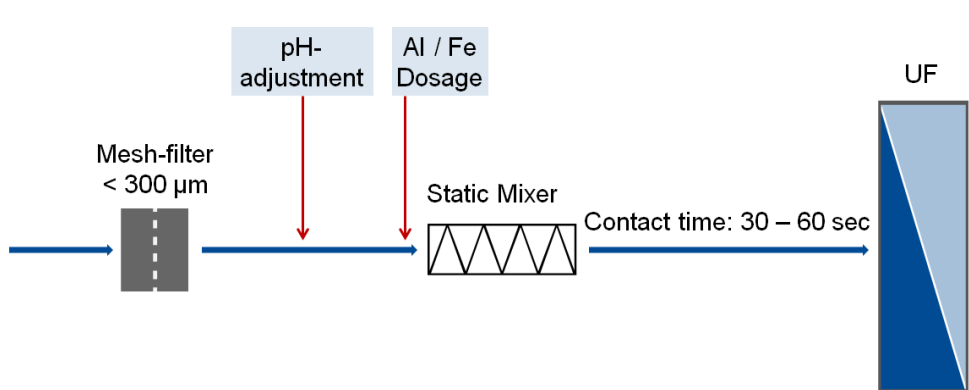

Figure 5.3-1 - Example 1: Pre-filter – Microflocculation – static mixer - UF

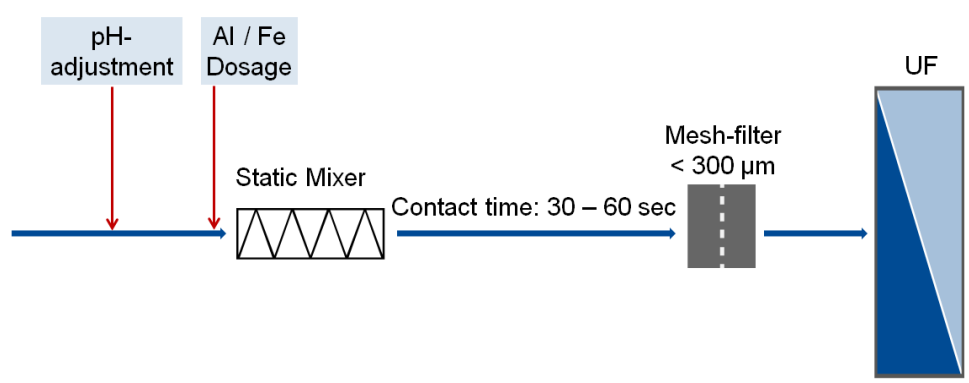

Figure 5.3-2 - Example 2: Microflocculation – static mixer – pre-filter – UF

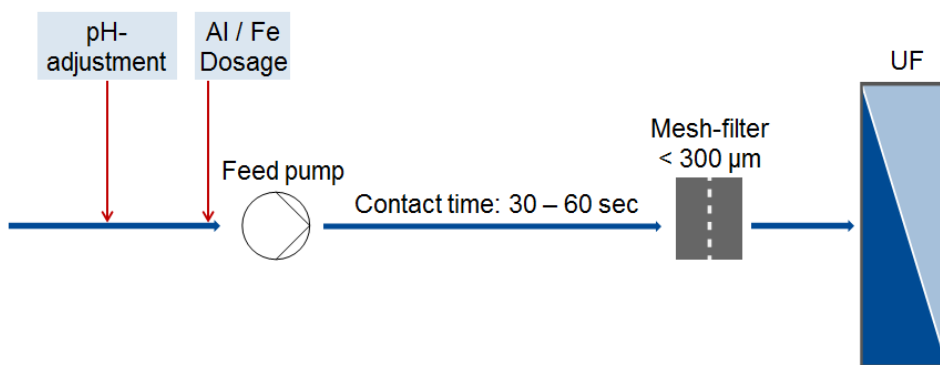

Figure 5.3-3 - Example 3: Microflocculation – feed pump – pre-filter – UF

## NOTE



### ATTENTION!

Observe the following guidelines!

- It is important to ensure proper mixing and adequate contact time. To achieve the best microflocculation results, the contact time for the chemicals should be adjusted to reflect the source-water quality (e.g. temperature) and the requirements regarding filtrate water quality (e.g. DOC, residual concentration of Al or Fe in the filtrate). Under no circumstances should microflocculation be allowed to take place in the membrane or on the filtrate side of the membrane (this would be the case if coagulants were not able to fully react with the UF feed water due to restrictions in timing and/or mixing and lead to unacceptable precipitation processes in or on the membrane surface).
- All chemicals added to the membranes and modules must at least comply with technical quality grade. Contaminated chemicals can cause irreversible fouling and are not permitted to use.
- When designing the microflocculation, please note that microflocculation processes are significantly slower at low temperatures (< 5 -10 °C). To counter this, DuPont™ recommends using polyaluminum chloride (PACl) which reacts significantly faster than other coagulants at low temperatures.
- When calculating the size and shape of the contact tank, it is important to choose a design that avoids short-circuiting in the tank.
- Special instructions must be followed for CEB and Clean-In-Place (CIP) and regular acid cleanings have to be performed once coagulants are introduced to the UF feed water.
- No organic coagulants or coagulation aids (e.g. polyelectrolytes) may be used either alone or in combination with inorganic coagulants since this may lead to severe, chemically irreversible fouling on the membranes which even CIP cleanings may be unable to remove. In certain special circumstances it may be possible to use substances of this type, but only if this has been tested and approved in writing by DuPont™ in advance.
- To avoid excessive dosing of coagulants, it is important to monitor and document the concentration of coagulants in the source water, feed and filtrate.

## 5.4 Continuous Chlorination in UF feed water

In some cases, continuous pre-chlorination is used as a form of pretreatment to combat bacterial growth in water treatment facilities. For a number of reasons, it is not recommended to apply pre-chlorination for UF.

Continuous chlorination of the UF feed water is in some cases considered to prevent micro- and macro-biological growth in the UF feed water intake structures, however, it is not recommended to apply such continuous chlorination upstream of the UF system. Instead, DuPont™ advises to implement other intake cleaning strategies such as shock chlorination (see below).

| <b>NOTE</b>   |  |
|---|--|
|  | <b>ATTENTION!</b><br>Observe the following guidelines! |

- Chlorine is a powerful oxidant which can lead to the formation of volatile chlorinated hydrocarbons in water chlorination processes. This by-product occurs as a result of free chlorine reacting with organic material. The best-known by-products are trihalomethanes (THMs), a class of chemicals that includes chloroform, which has been shown to cause cancer in laboratory animals, and chloramines, which are believed to trigger allergies, and which cause the chlorine smell associated with chlorinated swimming pools.
- THMs and other chlorinated hydrocarbons that are formed as by-products in the chlorination process are grouped under the parameter AOX, which stands for absorbable organic halogen compounds. There are threshold values for Wastewater discharge in many countries.
- Experience has shown that the use of continuous chlorination in the feed water to ultrafiltration is highly counterproductive. Chlorination of organic matter creates numerous tiny organic fragments which can cause blockage of the membrane pores.
- In addition, the organic fragments produced by chlorination also tend to be bioavailable, a situation that is compounded by the significant increase in the rate of bacterial growth in the water if the free chlorine is neutralized. Together, these factors lead to an increase in the formation of biofilms (biofouling) on any downstream equipment or processes (e.g. reverse osmosis membranes).
- For this reason, continuous chlorine dosing should not be used as a pretreatment stage.
- A better choice for pretreatment is a process known as shock chlorination, which involves adding a high dose of chlorine to the source-water for a short period of time at less frequent intervals.

## 6 Chemically Enhanced Backwash (CEB)

### 6.1 General Overview

A chemically enhanced backwash (CEB) is used to boost the effectiveness of a backwash. It is performed after a defined number of operating cycles

| <b>NOTE</b>   |   |
|---|---|
|  | <p><b>ATTENTION!</b></p> <p>Observe the following guidelines!</p> |

- The guidelines stipulated in the section on "Using Chemicals for CEB/CIP" must be observed. For most applications, acidic and caustic (with or without the addition of oxidants) CEBs have generally proved to be the best choice. Before using any other chemicals, it is necessary to contact DuPont™ to obtain written approval and information on permissible concentrations.
- If a CEB is executed with a reduced flux (less than 230 L/(m<sup>2</sup>h)), a backwash should be performed first. This enhances the effectiveness of the cleaning solution in the subsequent CEB.
- A CEB may only be performed using water of at least PES-UF filtrate quality or reverse osmosis permeate. The water used must be free of abrasive and membrane-blocking particles. When drawing water from the tank for a CEB, the same rule applies as for normal backwashes, e.g. ensure that no corrosion or erosion products that may have formed in the tank or in the pipes are washed into the module.
- CEB frequency depends on feed water quality and other operating conditions such as flux rate and recovery rate. The CEB is usually carried out several times a week.
- It is important to ensure that the CEB chemicals are injected into the system for a sufficiently long period of time to ensure that they are distributed evenly and homogeneously throughout the entire rack.
- The effectiveness of a CEB depends not only on the chemicals used, but also on the soaking time and the operating cycles and time intervals between CEBs. The sequence of the various CEBs should therefore be programmed as flexibly as possible.
- For the vast majority of applications, alkaline CEBs have proved to be the best choice for removing organic build-up and acid CEBs have been proven as the best solution for removing inorganic fouling.
- Since there is always the possibility of precipitation in an alkaline CEB, this must always be followed by an acid CEB. It is advised to operate the membrane system for one filtration cycle between a caustic CEB and an acid CEB to refill the backwash tank and neutralize the water in the membrane fibers.
- An alkaline CEB should always be performed in combination with acid as a caustic/acid CEB. Acid CEBs may be performed as a standalone procedure or in combination with caustic as a caustic/acid CEB.
- If iron-based coagulants are used in the pretreatment stage, the residue can only be removed by an acid CEB. If aluminum-based coagulants are used, then either acid or alkaline CEBs may be performed.
- Chlorine containing CEB solution rinsed out of the system should under no circumstances be mixed with acid CEB solutions (e.g. in a neutralization tank), since this could lead to the formation of toxic chlorine gas.

The CEB's mentioned in Table 6.2-1 or their combination - with defined frequencies - are used depending on the application and feed water quality. The following points must be considered during the programming or organization of the CEB sequences.



## 6.2 Types of CEB

| <b>NOTE</b>   |   |
|---|---|
|  | <p><b>ATTENTION!</b></p> <p>Observe the following guidelines!</p> |

- A caustic/acid CEB sequence is treated as a single CEB. In Table 6.2-1, this is designated as CEB 1 and is divided into an alkaline CEB 1.1 and an acid CEB 1.2. If an oxidant is added to the alkaline CEB 1.1, it is referred to as CEB 1.1 (B); if no oxidants are added, it is designated as CEB 1.1 (A).
- The acid CEB is designated as CEB 2 (Table 6.2-1). The acid CEB 2 is considered stand-alone, which means it is used independently from other CEB's to enable the effective removal of foulant build-up caused by inorganic water constituents or coagulants (e.g. FeCl<sub>3</sub>, PACl).
- The oxidant CEB is designated as CEB 3 (Table 6.2-1). CEB 3 is considered stand-alone, which means it is used independently from other CEB's. It is only required in applications involving the treatment of water discharged from a wastewater treatment plant.

*Table 6.2-1 - Organization of the CEB's*

|                        | <b>CEB 1</b>   |                      |                                       | <b>CEB 2</b>   | <b>CEB 3</b>                                       |
|------------------------|--|----------------------|---------------------------------------|--|--|
| <b>Note</b>            | Sequence of two chemical cleaning stages (CEB 1.1 and CEB 1.2): caustic followed by acid           |                      |                                       | Single stage, Performed separately from other CEBs         | Single stage, Performed separately from other CEBs |
| <b>Purpose</b>         | To clean off organic deposits and then to clean off inorganic deposits and/or remove precipitation |                      |                                       | To remove inorganic deposits (including coagulant residue) | Disinfection                                       |
| <b>Subprogram</b>      | CEB 1.1(A)   | CEB 1.1(B)           | CEB 1.2                               | -  | -  |
| <b>Characteristics</b> | Purely alkaline  | Alkaline + oxidative | Acid                                  | Acid   | Disinfection                                       |
| <b>Chemicals</b>       | NaOH   | NaOH und NaOCl       | HCl or H <sub>2</sub> SO <sub>4</sub> | HCl or H <sub>2</sub> SO <sub>4</sub>                      | NaOCl  |

Further advice for the programming of the control logic can be requested at DuPont™.

### 6.3 How a CEB is Performed

The CEB is essentially performed in a similar way to a backwash, i.e. filtrate flows from the filtrate side to the feed side.

In addition, a cleaning chemical is added to the filtrate to boost the effectiveness of the process. Figure 6.3-1 shows the basic sequence of steps generally used to perform a CEB based on typical values for the respective parameter settings. The chemicals are introduced into the system using a defined flux rate (referred to here as the injection flux rate) of approx. 120 L/(m<sup>2</sup>h) (71 GFD), which is lower than the backwash flux rate. To improve the distribution of the CEB solution within the rack, the injection of the solution must be divided into a "chemical injection to drain bottom" and a "chemical injection to drain top". The duration of the injection to drain bottom and injection to drain top must be at least 20% of the total duration of the chemical injection time in each case.

Once the rack has been completely filled with cleaning solution (controlled by the chemical injection time setting) the injection process is stopped and the UF rack is isolated by closing all inlet and outlet valves.

This marks the beginning of the soak period. Once the soaking time has elapsed, the chemical solution and the substances removed from the membrane must be washed out of the module(s)/rack with filtrate. This is achieved by means of a Backwash Drain Bottom (with a duration of approximately 30 seconds) followed by a Backwash Drain Top (also with a duration of approximately 30 seconds). The flux rate for rinsing out the solution should be 230 L/(m<sup>2</sup>h) (135 GFD) just like a normal backwash. Higher flux rates for rinsing are applicable under consideration of the limits as described in the respective product data sheets.

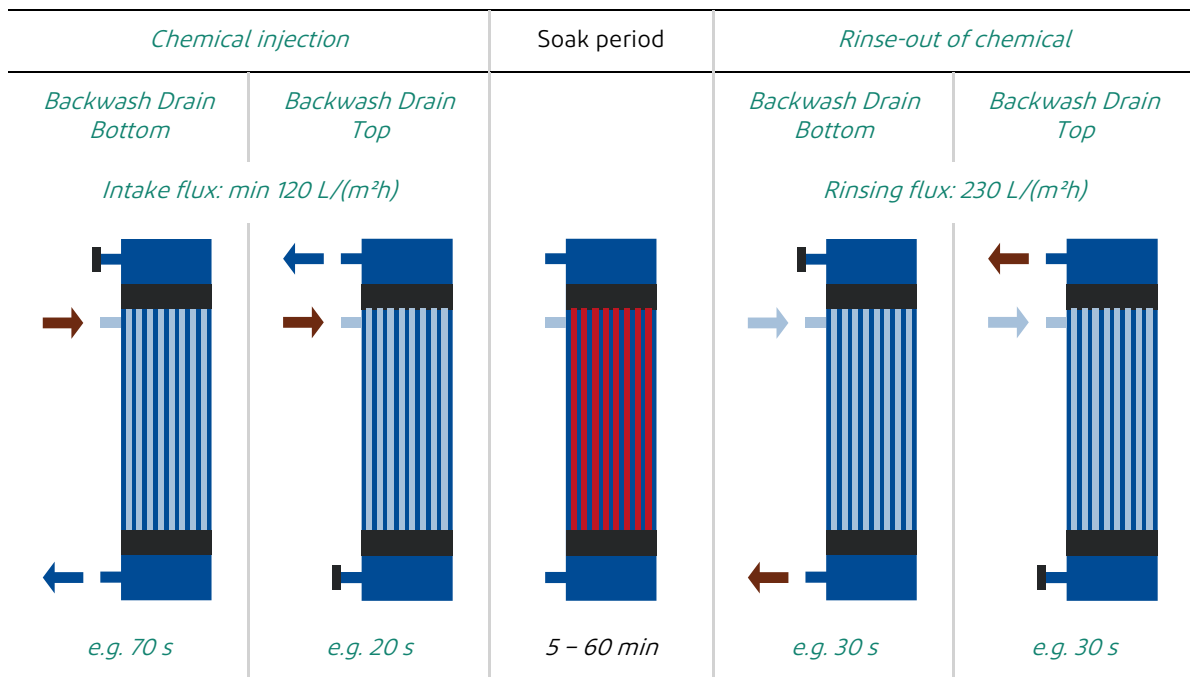

Figure 6.3-1 - Chemically enhanced backwash (CEB) process with typical parameters for an injection flux rate of 120 L/(m<sup>2</sup>h) (71 GFD)

## Chemically Enhanced Backwash (CEB)

The time required to wash the chemicals into the module(s)/rack in a CEB depends on the position of the chemical dosing points (referred to here as  $t_{ex}$  (= "**external time**", which is defined as the time required for the CEB solution to make its way from the chemical dosing point to the rack), installed mixing devices, and on the respective flow velocities in the backwash piping and in the piping systems built into the rack. At an injection flux rate of 120 L/(m<sup>2</sup>h) (71 GFD), the chemical injection time (measured from the moment the CEB solution enters the rack<sup>®</sup> until the entire rack<sup>®</sup> is completely filled) is approximately 60 - 90 seconds. This time period is referred to here as  $t_{int}$  (= "**internal time**" inside the rack).

The total chemical injection time total is the sum of  $t_{int}$  and the time period  $t_{ex}$  (see Figure 6.3-2). The precise figures for these two time periods should be calculated as part of the system commissioning process.

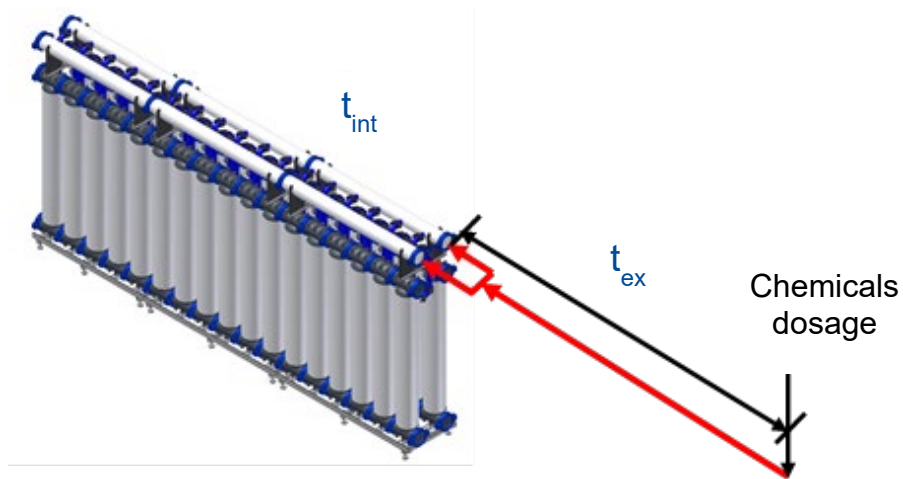

Figure 6.3-2 - Total chemical injection time during CEB

# 7 Chemical Clean-In-Place (CIP)

## 7.1 General Overview

The pressurized UF In-Out process is designed to maintain clean membrane state throughout the entire operation by both, hydraulic cleaning steps (backwash) and chemical cleaning steps (CEBs). The feed water can, however, contain contaminants (natural or introduced), which cannot be adequately removed by CEB.

A Clean-In-Place (CIP) procedure has been designed to restore membrane productivity for difficult to remove fouling and scaling. There are several different CIP chemicals and procedures available, depending on the nature of the foulant or scale. CIP is typically performed as a manual procedure; however, full automation of the CIP procedure(s) is also possible.

A CIP is performed by introducing a chemical solution into the modules and shutting down the individual UF-rack for a longer period of time than is required for conventional cleaning methods. One of the major differences to a CEB is that a CIP is characterized with the recirculation of different chemicals using a forward flush through the membranes back into a CIP tank followed by an extended soaking time (in some cases the feed tank can also be used as a CIP tank).

| <b>NOTE</b>  |   |
|--|---|
|  | <p><b>ATTENTION!</b></p> <p>Observe the following guidelines!</p> |

- A CIP should be performed if the permeability of the system falls below 100 –150 L/(m<sup>2</sup>h)/bar (4 – 6 GFD/psi) and if this drop cannot be reversed by performing a CEB. A CIP is rated as successful if the permeability of the system subsequent to the CIP is restored to a value of at least 70 – 80% of the reference value\* recorded after the commissioning of the ultrafiltration system.
- Only those chemicals specified in the section "Using Chemicals for CEB/CIP" may be used for a CIP, and only in conformance with the concentrations and soaking times specified. No other chemical(s) may be used unless prior written approval has been obtained from DuPont™ specifically agreeing to its use and stating the permissible concentration.
- The water used to prepare the CIP cleaning solution should be at least of drinking water quality. If reverse osmosis permeate is available, this should be used for the alkaline CIP. Please note that precipitation may occur in the CIP water, particularly if UF filtrate or water of drinking water quality is used for the alkaline CIP. An alkaline CIP must therefore always be followed by an acid CIP or alternatively by a standard acid CEB.
- The overall duration of the recirculation and soaking time of a CIP depends on the effectiveness of its cleaning results, though it should not exceed 12 hours.
- A conventional backwash should be performed prior to a CIP to ensure that the membrane surface is as clean as possible and to rinse out any foreign particles that may be contained in the piping of the modules or racks.
- When performing a CIP, ensure that the modules and racks being cleaned are disconnected from the rest of the main system.
- The CIP solution must be fed into the rack from the feed side of the modules/rack. This prevents any damaging substances which could cause fouling or scaling from entering through the filtrate side of the membranes during CIP recirculation.

---

\* Experience has shown that permeability falls during the initial running-in phase of a membrane, which generally lasts around one week, dropping from its initial level to a lower yet stable level of permeability which depends on a number of factors including the quality of the source-water. It is this subsequent, stable level that is classified as the reference value. The initial permeability of PES-UF modules lies somewhere in the range of approximately 700 L/(m<sup>2</sup>h)/bar (28.4 GFD/psi), while the reference permeability lies between 300 and 600 L/(m<sup>2</sup>h)/bar (12.2 – 24.4 GFD/psi) depending on the source-water quality.

## Chemical Clean-In-Place (CIP)

- In some applications it may be possible to improve the effectiveness of the cleaning process and reduce the soaking time by heating the CIP solution. If a system is available to heat the CIP solution, this system must observe the maximum permitted temperature of 40 °C and the maximum permitted rate of temperature change of 5 °C/min. A significant amount of energy is required to heat the solution and the process of ensuring compliance with the maximum 5°C/min temperature change rate can be relatively complicated. Heating of the CIP solution is not necessary in the vast majority of application and is therefore not recommended when using PES-UF modules.
- Ensure adequate ventilation of the area before and while using cleaning chemicals.
- When preparing the chemical solution in a CIP tank (mixing together the cleaning chemical and water), the chemicals must always be added to the tank of water, not the other way around. Adding water to concentrated chemicals could cause a violent reaction.
- It is important to ensure that the CIP chemicals are recirculated in the system for a long enough period of time to ensure that they are distributed evenly and homogeneously throughout the entire rack in the concentration required in each case. If the concentration falls below the required value, more of the chemical must be added.
- Note that the concentration of the CIP solution will be diluted by the water stored in the rack including the manifold (known as the "hold-up volume") and that this hold-up volume may lead to precipitation in the case of an alkaline CIP. When performing a CIP using reverse osmosis permeate, it may therefore be a sensible idea to empty the rack including the manifold before injecting the CIP solution.
- To increase the efficiency of a CIP cleaning, DuPont™ recommends performing multiple successive cleaning steps using different chemicals.
- If using a coagulant in the pretreatment stage, or if there are concerns that metals may have accumulated on the membrane surface, it is essential to perform an acid CIP before any CIP or disinfection process that involves oxidants in order to optimize the cleaning efficiency and to prevent coagulant from being deposited on the membrane. Ensure that the acid CIP solution has been completely rinsed out of the system before performing the oxidant CIP or disinfection process.
- Chlorine-containing CIP solutions should under no circumstances be mixed with acid CIP solutions (e.g. in a neutralization tank), since this could lead to the formation of toxic chlorine gas.

## 7.2 Establishing CIP Recirculation

The CIP tank must be designed large enough to ensure that the minimum level of water delivers sufficient initial pressure to the intake side of the CIP pump and that the previously empty pipes of the recirculation system can be filled. The total volume of the CIP tank is therefore obtained by adding together the following partial volumes:

- Empty volume of the piping from the top feed to the module/rack incl. manifold (V1)
- Empty volume of the filtrate piping (V2)
- Empty volume of the piping from the bottom feed to the module/rack incl. manifold (V3)
- Volume required to protect the CIP pump from running dry (V4)
- In seawater applications the UF rack has to be drained prior to CIP!

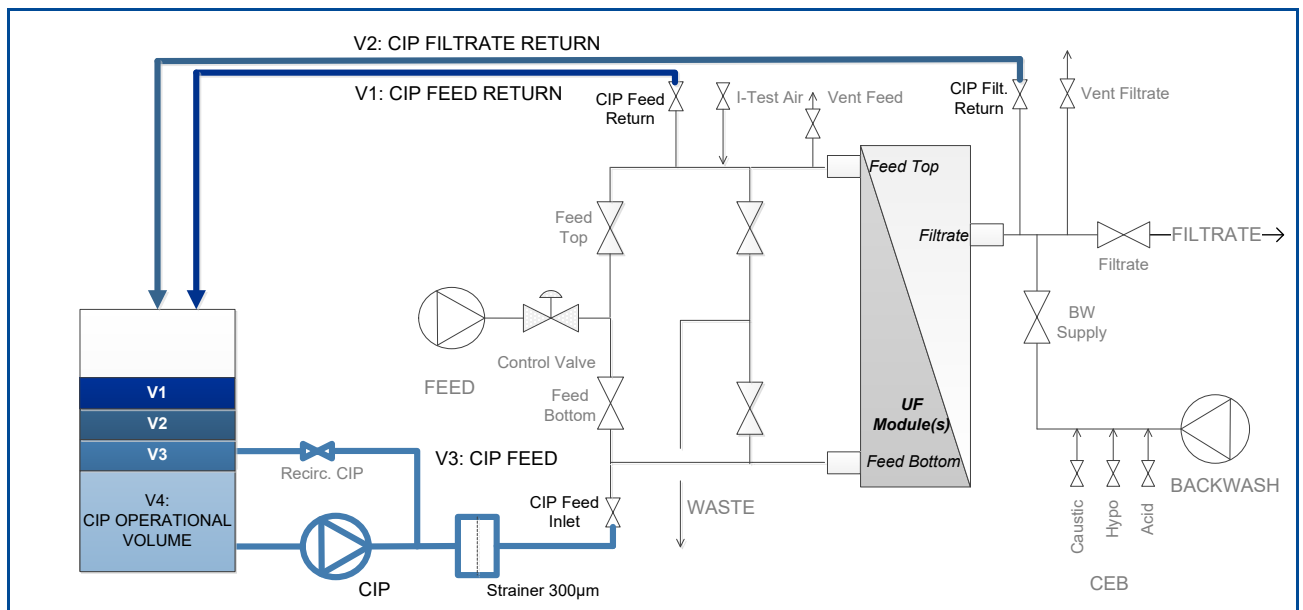

Figure 7.2-1 - Partial volumes for determining the size of the CIP tank

To protect the membranes from damaging particles, it is important to install a screen filter with a minimum cut-off of 300 µm in the recirculation system or at the point where the CIP solution is fed into the system. The recommended volume flow rate for cleaning all PES-UF modules is at least 25 L/(m<sup>2</sup>h) (12 GFD), the maximum hydraulic pressure loss 1 bar /14.5 psi).

[Design recommendation for the CIP cleaning pump capacity:

Nb of modules x surface area / module x 25 L/(m<sup>2</sup>h) (12 GFD) = volume flow rate @ minimum 1 bar]

## 7.3 How a CIP is Performed

### 7.3.1 Preparing the Chemical Solution for a CIP

1. The CIP tank (or feed tank) is filled with UF filtrate, reverse osmosis (RO) permeate or drinking water. If available, RO permeate should be used for the alkaline CIP.
2. The cleaning chemicals are added to the water-filled CIP tank, not the other way around.
3. The chemical solution is mixed using a mixer or a special recirculation system.

After mixing, check that the pH value and concentration of the solution correspond to the target values. It is important to ensure that the concentrations do not exceed the maximum concentrations specified in DuPont™ IntegraTec™ P Series | PES In-Out specific product documentation.

4. (In seawater systems, there must be a rack draining step at this point).
5. If a heating system is to be used to heat the chemical solution, the heating process may not commence until the chemical solution has begun recirculating through the modules. Significant differences in temperature between the chemical solution and the water inside the modules could lead to stress cracks in the module and should therefore be avoided. Do not exceed the maximum permitted rate of temperature change or the maximum permitted operating temperature for the modules.

### 7.3.2 Preparing for a CIP Process

1. For a manual CIP, ensure that the valves are in the correct positions and that the connections are set properly for the cleaning cycle:
  - Cleaning solution inflow = feed bottom header connection
  - Cleaning solution outflow = feed top header connection
  - Filtrate outflow = filtrate
2. The cleaning solution may be pumped either in forward flush mode or in filtration mode. However, the CIP method described should under NO circumstances be used in the backwash direction since this could cause large-scale irreversible contamination or bacterial growth on the filtrate side.

## 7.3.3 Recirculation and Soaking time

1. In the first stage, recirculation should only take place via the feed side for at least 60 minutes in order to perform initial cleaning of just the fiber lumen. The filtrate valve is closed during this procedure.
2. Injection of the chemical solution into the fiber lumen on the feed side is triggered by starting the CIP cleaning pump (Figure 7.3-1). Set the minimum volume flow rate in accordance with the section "Establishing CIP Recirculation". It is important to ensure a feed side venting.

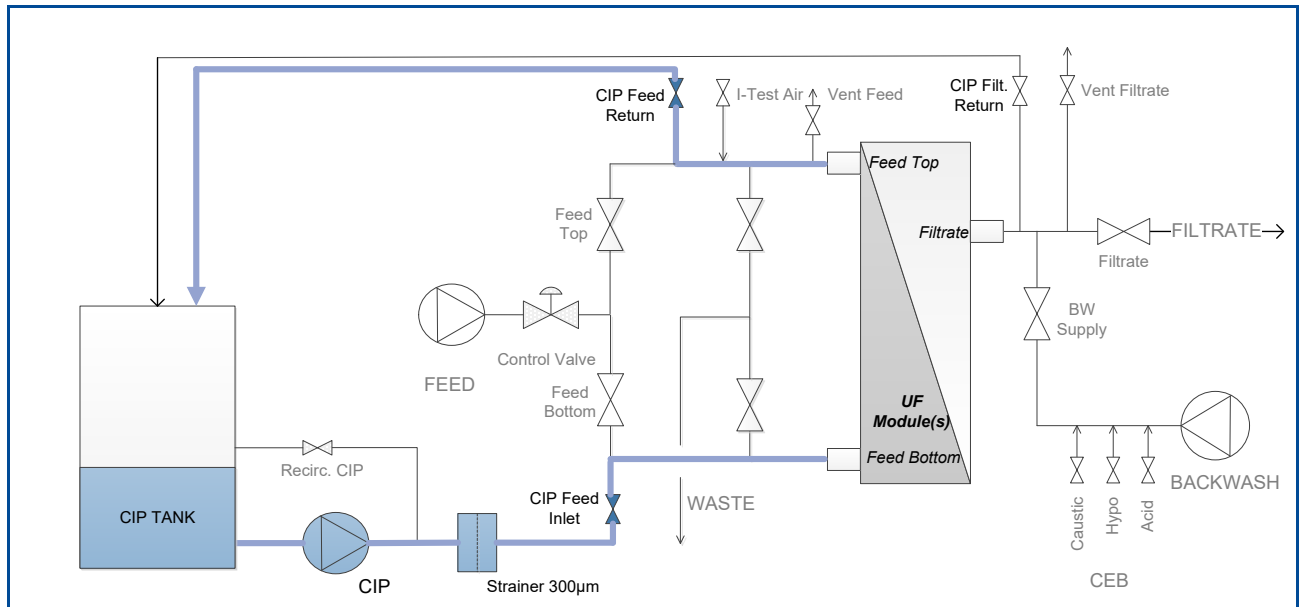

Figure 7.3-1 - Recirculation on the feed side

3. If the chemical solution is to be heated, it should be slowly heated to 30-35°C while it is recirculating through the system. Do not exceed the maximum permitted rate of temperature change or the maximum permitted operating temperature for the modules.
4. The readings of the temperature, pH value and concentration of the cleaning solution are to be continuously monitored and documented to ensure that they remain within the required range and within the scope of the permissible operating conditions. Long periods of recirculation could potentially heat the solution to a level above the maximum permitted temperature due to waste heat from the pump entering the equation. If the temperature exceeds the required level, this must be countered by adding fresh UF filtrate, RO permeate or drinking water. The pH value and chemical concentration should be adjusted to meet requirements.
5. Once at least 60 minutes have passed with the solution recirculating exclusively through the feed side, the process moves on to a second stage in which the filtrate side is incorporated in the recirculation process. The filtrate valve is now opened, and CIP fluid is allowed to recycle through the feed top port and through the filtrate port simultaneously. Normally, the flow rates should be of similar dimension which is acceptable for the CIP process. Recycle flow rates should nevertheless be verified for similarity during the first CIP. Flow rate ratios are allowed to differ as much as 20%-80% for compliance with this CIP procedure.



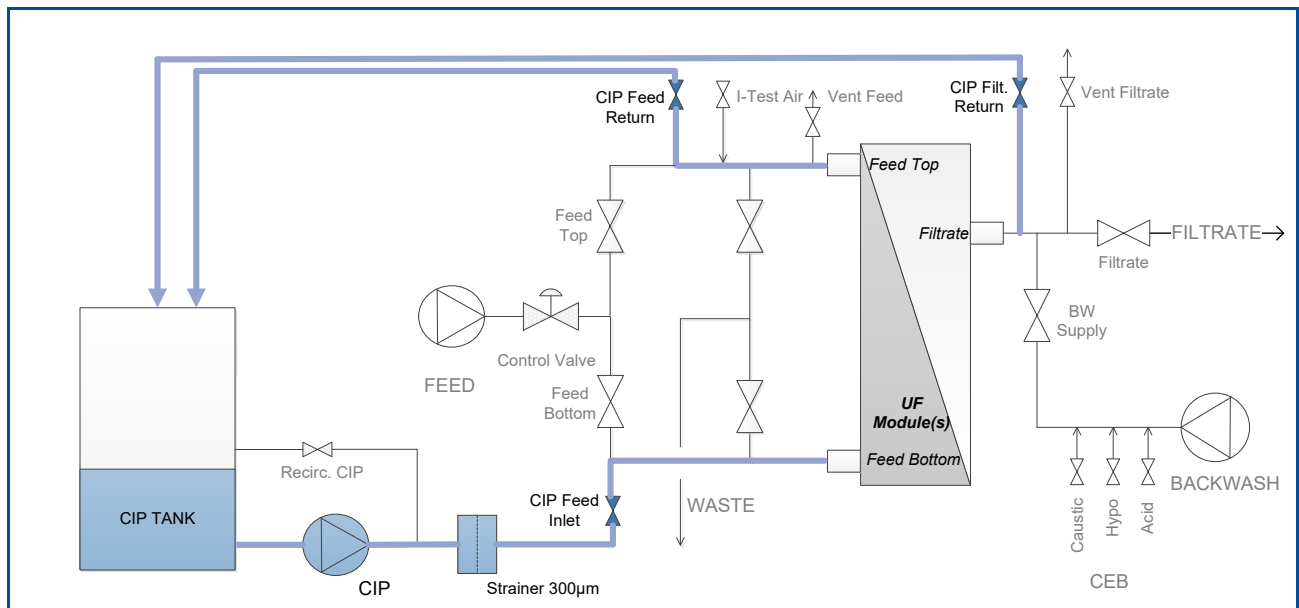

Figure 7.3-2 - Recirculation on feed and filtrate sides

6. During the entire recirculation process, which should last for at least a further 60 minutes, it is important to ensure that the chemical solution recirculates through both - the feed and filtrate - sides.
7. Once the chemical solution has been recirculating through the system for approximately 2 hours, the process moves on to a third stage which alternates between soaking periods and recirculation through the feed and filtrate sides. In this third stage, the cleaning pump is stopped, the heating element is switched off, and the feed side valves are closed (ensure venting all the time).
8. As a rule of thumb, 60 minutes is sufficient for the soaking time prior to the next recirculation, though longer soaking times may be necessary in the case of stubborn fouling or scaling. To maintain a high temperature during lengthy soaking times, a brief recirculation process lasting approximately 5 minutes should be conducted midway through the soaking time.
9. The next steps involve alternating between recirculation through the feed and filtrate sides and soaking times. Note that the duration of a recirculation period should not exceed 60 minutes and the overall duration of recirculation and soaking time should not exceed 12 hours.

## 7.4 Preparing to Rinse out the Rack/System

1. Once the recirculation process has been completed, the chemical solution is drained from the CIP tank. Where required, the solution should be neutralized before being discharged. Ensure that the discharged solution complies with all the local regulations regarding discharges into the sewage system. Before emptying the CIP tank, ensure that the feed side valves of the modules/racks are closed.
2. Once the CIP tank is empty, it can then be refilled with UF filtrate, RO permeate or drinking water ready for the next rinsing process. It is not necessary to use RO permeate to rinse out the system even if this is available.

## 7.5 Rinsing out the Rack/System

After completion of the soaking period, the standard CEB rinsing procedure is used to rinse out the remaining chemicals.

The following diagrams show the two rinsing operating modes "Rinsing Drain Bottom" and "Rinsing Drain Top". Figure 7.5-1 shows a Rinsing Drain Bottom (RDB) step in which the backwash water (filtrate) exits the module at the bottom feed/drain port, while Figure 7.5-2 shows a Rinsing Drain Top (RDT) step in which the backwash water exits the module at the top feed/drain port.

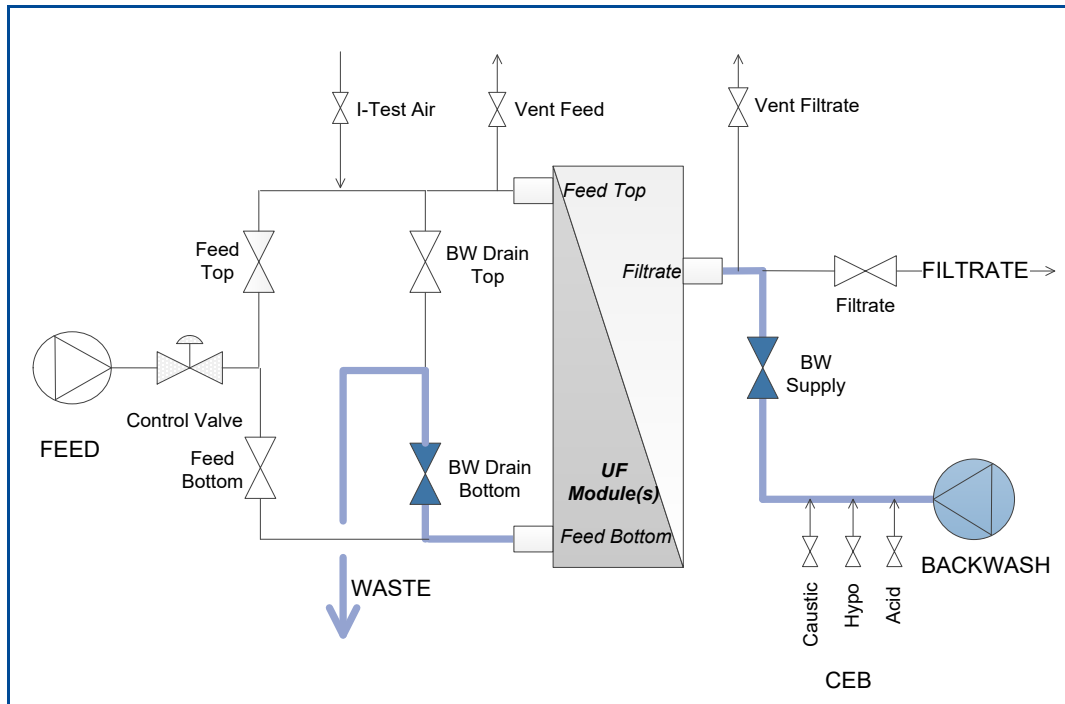

Figure 7.5-1: Rinsing of CIP chemicals in Drain Bottom mode

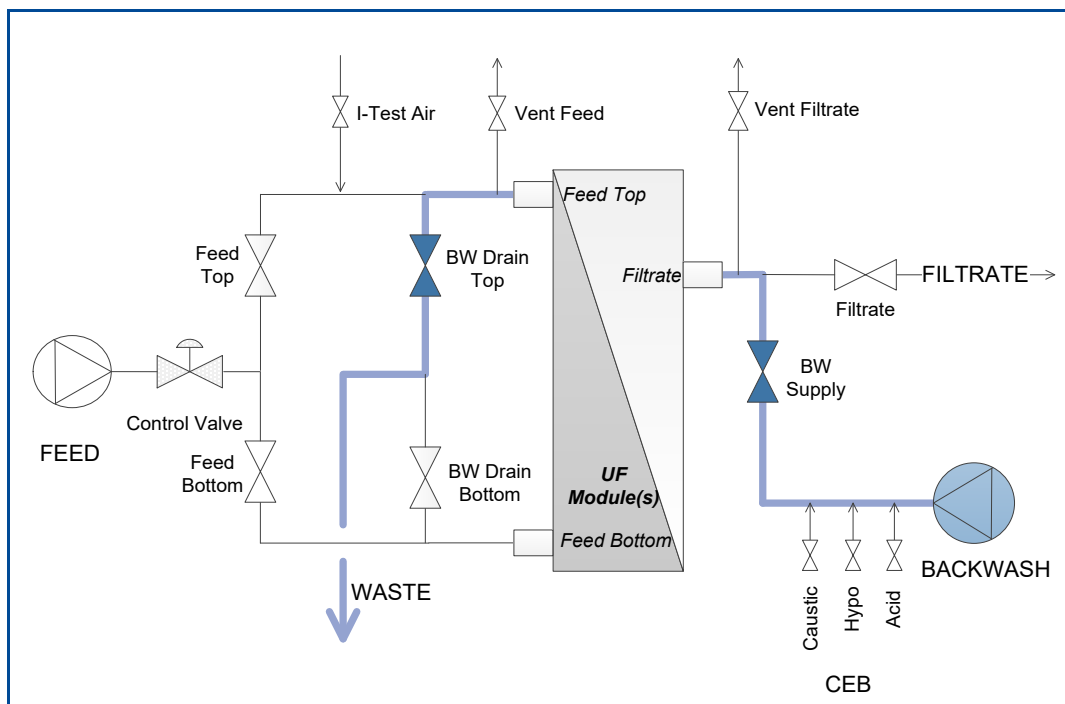

Figure 7.5-2: Rinsing of CIP chemicals in Drain Top mode

## Chemical Clean-In-Place (CIP)

If the chemical solution has previously been heated, the first step before beginning the rinsing process is to equalize the respective temperatures of the rinsing water and the chemical solution contained within the module/rack by stopping the CIP pump and waiting for the temperature inside the UF rack to return to ambient conditions. Alternatively, colder water can be added at slow rate to the CIP tank towards the end of the CIP recirculation. Significant differences in temperature between the rinsing water and the chemical solution inside the modules/rack could lead to stress cracks in the module and should therefore be avoided. Do not exceed the maximum permitted rate of temperature change or the maximum permitted operating temperature for the modules

Required duration of the CIP rinsing procedure must be determined by sampling of discharge water for residual chemicals (e.g. pH or free chlorine) and evaluated based on project specific permissible contaminant concentration.

During the rinsing process, the flow rate (flux rate), the temperature and the TMP (transmembrane pressure) should be monitored and documented in order to calculate the permeability and check the cleaning efficiency of the preceding cleaning process.

Once the rinsing process has been completed, the permeability should be monitored and documented in filtration mode in order to check the efficiency of the CIP. This should be conducted after every CIP, even if two CIPs are performed in succession.

## 8 Using Chemicals for CEB/CIP

### 8.1 Differences between CIP und CEB

CEB and CIP are both chemical cleaning processes to restore membrane permeability by removing a hydraulically irreversible fouling layer. The CEB is used typically once daily which is projected as sufficient to maintain satisfactory membrane permeability throughout the lifetime of the plant. The feed water can, however, contain contaminants (natural or introduced), which can not be adequately removed by CEB.

CIP is used when membrane permeability can no longer be recovered by CEB. While a standard CIP can contain the same chemicals as a CEB, chemicals are recirculated and soaked at stronger concentrations, for extended durations and are in some rare cases heated, thus thoroughly cleaning the membrane surface and pores until clean conditions are reached. Special CIP cleaning agents can also be used in instances where standard CIP chemicals are not sufficiently able to clean the membranes. CIP is mostly applied as a manual procedure as it is not expected to occur frequently, however, the CIP can also be fully automated in the plant's SCADA system.

| <b>NOTE</b>  |   |
|--|---|
|  | <p><b>ATTENTION!</b></p> <p>Observe the following guidelines!</p> |

In addition to the instructions stipulated in this section, the performance of CEBs and CIPs is also subject to the permissible operating conditions stipulated in the individual sections.

### 8.2 Permissible Chemicals and Operating Conditions

The parameters of a CEB and, in particular, a CIP – for example, the type of cleaning chemical – should be tailored to the type of membrane fouling/scaling and thus to the quality of the water being treated. Three different types of water have been defined for this purpose:

- Water type A: Ground water and surface water
- Water type B: Discharge water from a municipal Wastewater treatment plant (secondary effluent)
- Water type C: Sea water

| <b>NOTE</b>   |   |
|---|---|
|  | <p><b>ATTENTION!</b></p> <p>Observe the following guidelines!</p> |

- The permissible chemicals and operating conditions for the different types of water are listed in Table 8.2-1 for the CEB and Table 8.2-2 for the CIP. The only chemicals that are permitted for use in CEB and CIP are the chemicals listed here, and only in the concentrations and soaking times specified in the tables. Written approval must be obtained from DuPont™ before using any other chemicals (e.g. specially designed membrane cleaners).
- All chemicals added to the membranes and modules must comply with at least “technical quality grade”. Contaminated chemicals can cause irreversible fouling and are not permitted.
- With the concentrations and soaking times defined in Table 8.2-1 and Table 8.2-2 the chemicals listed here are generally a very effective choice for the CEB/CIP of PES-UF membranes, though in some cases they must be further adapted/optimized to cater to special source water situations. Should this be necessary, the modification of the parameters must be carried out in consultation with DuPont™.
- Conducting an alkaline CEB/CIP may potentially lead to precipitation, though generally only to a minor extent. This precipitation can be removed by the subsequent acid CEB/CIP.
- The use of chlorine by itself without the addition of caustic is only required for system disinfection or system shutdowns. Since the potential for bacterial growth is far higher in Wastewater applications than in applications involving other types of water, systems used to treat Wastewater should be disinfected once a week in accordance with Table 8.2-1.

The organic acids (citric acid/oxalic acid) can be used to enhance the removal of inorganic foulant in the CIP (not in CEBs) and the surfactant sodium lauryl sulfate can be used to help remove organic foulant in an alkaline CIP.

The UF system does not retain salts. Consequently, the salt concentration in the UF filtrate remains unchanged in sea water applications and applications with high salinity. If UF filtrate is used for CEB/CIP in sea water applications, the high magnesium concentration (1,200 – 1,600 mg/l) means that magnesium hydroxide ( $Mg(OH)_2$ ) precipitation begins to occur as soon as the dosage of  $OH^-$  ions in the form of caustic soda (NaOH) reaches approximately 2-5 mmol/l (exact dosages can be determined by titration). This quantity of dosed NaOH corresponds to an increase in the pH value to approximately 9.5 – 9.7. As the dosing of caustic continues, the quantity of  $Mg(OH)_2$  precipitation increases up until the point at which there is virtually no magnesium left in the water. The pH value does not increase any further during this process. As a result of the very high magnesium concentration, the level of precipitation increases substantially if dosing is continued.

- When using ultrafiltered sea water for a CEB, we specifically advise against using NaOH dosages in excess of 2 mmol/l or setting the pH value > 9.5 – 9.7.
- If the UF system is being used as a pretreatment stage for reverse osmosis (for example in a sea water desalination or Wastewater reuse facility), RO permeate must be used for every alkaline CIP (with or without oxidants) in order to avoid precipitation and maximize the effectiveness of the CIP. For the same reasons, RO permeate is recommended to be used for an alkaline CEB (whether this is performed with or without oxidants). To reduce the use of RO permeate, UF filtrate can be used to rinse out the system after the CEB.

The key factors in using chemicals to remove irreversible fouling or scaling are, firstly, the required contact between the chemical cleaning solution and the membrane foulant and, secondly, the interaction between variables such as concentration, recirculation, soaking time and temperature. The vast majority of cases also feature a combination of different types of foulant or scalant, which means that multiple cleaning steps are required to remove it. The use of chemicals at low temperatures reduces the effectiveness of the cleaning process and requires longer soaking times and/or higher concentrations

Table 8.2-1 - Chemicals, Concentrations and Soaking times for CEBs

| Chemicals    |  | Water type A:<br>Ground water and surface water | Water type B:<br>Discharge water from a municipal wastewater treatment plant | Water type C:<br>Seawater | Notes   |  |
|--------------|--|---|--|---------------------------|---|--|
| Inorganic    | Hydrochloric acid (HCl)                          | pH-value  | 1 < pH < 2.5   | 1 < pH < 2.5              |   |  |
|              |  | typical   | pH 2.3   | pH 2.3                    |   |  |
|              |  | Soaking time                                    | min. 10 - 60   | 10 - 60                   |   |  |
|              | Fouling Scaling                                  | typical   | 15   | 15                        |   |  |
|              |  | pH-value  | 1 < pH < 2.5   | 1 < pH < 2.5              |   |  |
|              |  | typical   | pH 2.3   | pH 2.3                    |   |  |
| Organic      | Sulphuric acid (H <sub>2</sub> SO <sub>4</sub> ) | Soaking time                                    | min 10 - 60  | 10 - 60                   |   |  |
|              |  | typical   | 15   | 15                        |   |  |
|              |  | pH-value  | 12 ≤ pH ≤ 13   | 12 ≤ pH ≤ 13              | 9.5 ≤ pH ≤ 9.7  |  |
|              | Caustic (NaOH)                                   | typical   | pH 12  | pH 12                     | pH 9.5  | Seawater:                              |
|              |  | Soaking time                                    | min 10 - 60  | 10 - 60                   | 10 - 60   | using RO permeate for CEB pH 12.3 (12) |
|              |  | typical   | 10   | 10                        | 10  |  |
| Fouling      | Sodium hypochlorite (NaOCl)                      | pH-value  | 12 < pH < 13   | 12 < pH < 13              | 9.5 < pH < 9.7  |  |
|              |  | typical   | pH 12  | pH 12                     | pH 9.5  |  |
|              |  | Concentration                                   | mg/L   | max. 50                   | max. 200  | Seawater:                              |
|              | Caustic (NaOH)                                   | typical   | mg/L   | 20                        | 20  | using RO permeate for CEB pH 12.3 (12) |
|              |  | Soaking time                                    | min  | 5 - 60                    | 5 - 60  |  |
|              |  | typical   | min  | 7                         | 7   |  |
| Disinfection | Sodium hypochlorite (NaOCl)                      | Concentration                                   | mg/L   | > 1 mg/L < 10             | The specified concentrations must be reached in the discharged rinse water at the end of the soaking time |  |
|              |  | Soaking time                                    | min  | 30                        |   |  |
|              |  | Frequency:                                      |  | 1x per week               |   |  |

Table 8.2-2 - Chemicals and Concentrations for CIPs (overall duration of soaking time and circulation max. 12h)

| Chemicals       | Water type A:                         |   | Water type B:           |                         | Water type C:           |                         | Notes                        |
|-----------------|---------------------------------------|---|-------------------------|-------------------------|-------------------------|-------------------------|------------------------------|
|                 | Ground water and surface water        | Discharge water from a municipal wastewater treatment plant | Seawater                |                         |                         |                         |                              |
| Inorganic       | Hydrochloric acid (HCl)               | pH-value:<br>typical:                                       | 1 < pH < 2.5<br>pH 2    | 1 < pH < 2.5<br>pH 2    | 1 < pH < 2.5<br>pH 2    | 1 < pH < 2.5<br>pH 2    |                              |
|                 | Sulphuric acid (H2SO4)                | pH-value:<br>typical:                                       | 1 < pH < 2.5<br>pH 2    | 1 < pH < 2.5<br>pH 2    | 1 < pH < 2.5<br>pH 2    | 1 < pH < 2.5<br>pH 2    |                              |
|                 | Citric acid                           | pH-value:<br>typical:                                       | 1 < pH < 2.5<br>pH 2    | 1 < pH < 2.5<br>pH 2    | 1 < pH < 2.5<br>pH 2    | 1 < pH < 2.5<br>pH 2    |                              |
| Fouling Scaling | + hydrochloric acid<br>or Citric acid | Concentration:<br>typical:                                  | max. 10<br>4<br>4       | max. 10<br>4<br>4       | max. 10<br>4<br>4       | max. 10<br>4<br>4       |                              |
|                 | Oxalic acid                           |   | 4                       | 4                       | 4                       | 4                       |                              |
|                 | Caustic soda (NaOH)                   | pH-value:<br>typical:                                       | 12 < pH < 13<br>pH 12.5 | 12 < pH < 13<br>pH 12.5 | 12 < pH < 13<br>pH 12.5 | 12 < pH < 13<br>pH 12.5 | Use RO permeate if available |
| Organic         | Sodium hypochlorite (NaOCl)           | pH-value:<br>typical:                                       | 12 < pH < 13<br>pH 12   | 12 < pH < 13<br>pH 12   | 12 < pH < 13<br>pH 12   | 12 < pH < 13<br>pH 12   | Use RO permeate if available |
|                 | + Caustic soda (NaOH)                 | NaOCl:<br>typical:  | mg/L<br>mg/L            | mg/L<br>mg/L            | mg/L<br>mg/L            | mg/L<br>mg/L            |                              |
|                 | Sodium lauryl sulfate                 | pH-value:<br>typical:                                       | 12 < pH < 13T<br>pH 12  | 12 < pH < 13T<br>pH 12  | 12 < pH < 13T<br>pH 12  | 12 < pH < 13T<br>pH 12  |                              |
| Fouling         | + Caustic soda (NaOH)                 | Concentration:<br>typical:                                  | max. 10<br>4            | max. 10<br>4            | max. 10<br>4            | max. 10<br>4            |                              |
|                 | Sodium hypochlorite (NaOCl)           | Concentration:<br>typical:                                  | g/L<br>g/L              | g/L<br>g/L              | g/L<br>g/L              | g/L<br>g/L              |                              |
|                 | Sodium hypochlorite (NaOCl)           |   |                         |                         |                         |                         |                              |
| Disinfection    |                                       |   |                         |                         |                         |                         |                              |
|                 |                                       |   |                         |                         |                         |                         |                              |

## 9 Design and Construction

Following DuPont™ provide estimates and rough approximations for the design and construction of PES-UF systems. The given information is based on long-term experience in treating different types of source water.

The following parameters are the minimum basis needed to perform a feed water analysis:

- Suspended particulate matter:
  - Turbidity / Total Suspended Solids (TSS)
- Dissolved organic matter:
  - DOC/TOC and specific UV absorbance at 254 nm,
  - For Wastewater: Chemical Oxygen Demand (COD) and Biological Oxygen Demand (BOD)
- Inorganic compounds:
  - Ca, Mg, alkalinity / HCO<sub>3</sub><sup>-</sup>, Fe, Mn, Al
- pH value
- Temperature
- Seasonal changes

If the UF feed water quality and temperature of the source water is subject to seasonal changes, details on the range of fluctuation are also required for the analysis (ideally in the form of a distribution, otherwise at least stating the minimum, maximum and median values). Other important information for surface waters (and for source waters affected by surface waters) includes the duration and impact of heavy rain and flooding events.

The collection of detailed information to the project specific pretreatment steps and/or intake situation (e.g. for seawater systems) is recommended.

Avoiding errors in the design and construction of a PES-UF system is fundamental to achieving smooth, trouble-free operation when the plant is completed. It also reduces the risk of damaging the membranes and modules or suffering irreversible loss of performance. Proper compliance with the following guidelines is a key prerequisite for making successful claims under the warranty should this become necessary.



## NOTE



### ATTENTION!

Observe the following guidelines!

- The design and construction of any UF system should be based on state-of-the-art technology and in accordance with good engineering practices.
- The system should be specifically designed to avoid any pneumatic and/or hydraulic pressure surges or siphoning effects. All UF systems should include the following components and observe the following requirements:
- The system should include a means of controlling the feed and backwash volume flow rates (e.g. using frequency-controlled pumps or control valves with PID controllers). For the backwash pump controller, it is important to ensure that the set point value for the volume flow is reached within 5 - 7 seconds (time depends on pump capacity and valve dimension).
- The actuators of all (butterfly) valves should be equipped with air throttling valves to control the opening and closing procedure. Air/water hammer can occur if the valves open or close too abruptly.
- Air vent valves must be provided to vent the dead ends of the rack feed and filtrate headers to prevent pressure surges caused by air trapped in the dead end. Further air vent valves should be provided on all higher sections of the rack piping and connecting pipework.
- The rinse water piping must be equipped with vacuum breakers (air intake valves).
- The switching circuits of the pumps and valves must be designed to ensure that no pressure surges are produced in the system, e.g. the pumps and valves should be actuated in a controlled sequence at intervals of approximately one second so that pumps are never running against closed valves.
- Any change of operating mode that involves a switch between the feed and backwash pump, including the switching of the required valves (e.g. backwash to filtration) must include an idle interval of approx. 5 - 7 seconds between the completion of one operating mode and the activation of the subsequent operating mode.
- Every module in a membrane rack must be operated under the same operating conditions.
- When designing and constructing an ultrafiltration system, it is important to ensure that there are no dead spaces, particularly on the filtrate side, which could encourage microbial growth. For the same reason, it is essential that there is no direct connection between the feed and filtrate sides which could create a bypass between the two sides of the filtration process.
- When designing/constructing an ultrafiltration system, it is also important to ensure that no corrosion or erosion products from the feed tank, backwash tank or piping can be rinsed back into the modules. For this reason, the tanks used for source water, filtrate/backwash and Clean-In-Place (CIP) must be made of non-corroding materials which will not release any contaminants or damaging (e.g. abrasive) substances into the water. The same applies to the piping and all other components installed within the ultrafiltration system.
- The dosing pumps must be designed and scaled to meet the concentrations and pH values required for CEBs.
- Only air release valves may be used. The use of combination vacuum valves/air release valves or valves designed purely for vacuum breaking is not recommended (with the exception of vacuum breakers in the rinse water piping) in order to prevent air from accidentally entering the system.
- The use of gap-type/edge filters is not recommended for the required pre-filter protection stage, which should have a maximum mesh size of 230 µm for membranes of the Multibore™ family with an inner diameter of 0.7 mm, or up to 300 for larger ID membranes. The pre-filter should be automatically backwashable.
- It is important to protect the water in the filtrate/BW tank and connecting pipework from direct sunlight and exposure to light in order to prevent excessive heating and avoid exposure to sunlight which could pose a risk of promoting bacterial and/or algae growth.
- Sealed filtrate/backwash tanks with air filters must be used to prevent microbiological contamination.

UF membranes cannot reject dissolved substances. This physical fact should be taken into account for all parameters (SDI<sub>15</sub><sup>†</sup>, turbidity<sup>‡</sup>, etc.) when designing a UF system (including the effect on any downstream treatment processes) and when measuring UF filtrate quality.

- We recommend providing three chemical dosing points for CEBs for each membrane train (= independent backwashable unit of several modules). These dosing points should be as close to the train as possible. Experience has shown that it is sensible to place the acid dosing unit furthest upstream in the system. Any precipitation that builds up on the other dosing units further downstream can then be removed by means of acid dosing. It is important to ensure that the chemicals are properly mixed into the flow of water (mixing devices should be used if required). This system offers numerous advantages over the alternative of a central dosing unit:
- Reduces the volume of water that must be replaced when dosing and rinsing, thereby reducing dosing time.
- Avoids the mixing of different chemicals in the backwash piping which could otherwise occur if two CEBs were performed one immediately after the other for two different trains.
- Reduces chemical consumption and provides higher recovery rates because less water is used.
- Introduces fewer variables for the control system.
- When using coagulants in the pretreatment on an iron basis, residuals can only be removed with an acid CEB.
- UF systems with PES-UF Modules and UF systems with T-Rack™ should adhere to the basic flow diagrams shown in the following diagrams (see Figure 8.2-1 to Figure 8.2-4).

---

† SDI<sub>15</sub>; (fouling index) measurement according to ASTM D4189-94

‡ Turbidity to be measured using analytical sensors and procedures in compliance with ISO 7027 and/or, Standard Methods 2130 B.

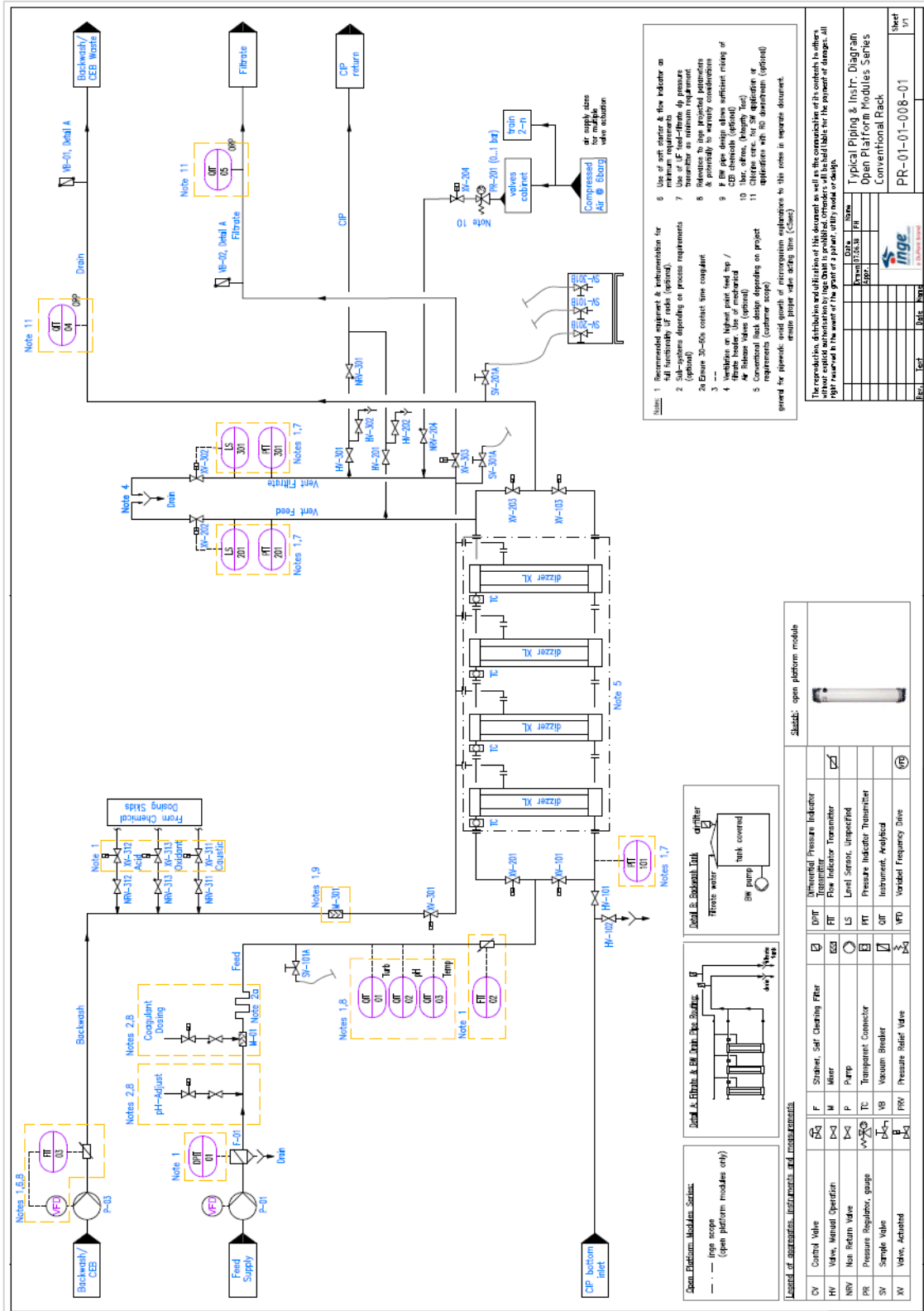

Figure 8.2-1 - Flow Diagram for a UF System PES-UF Modules for Open Platform (version conventional)

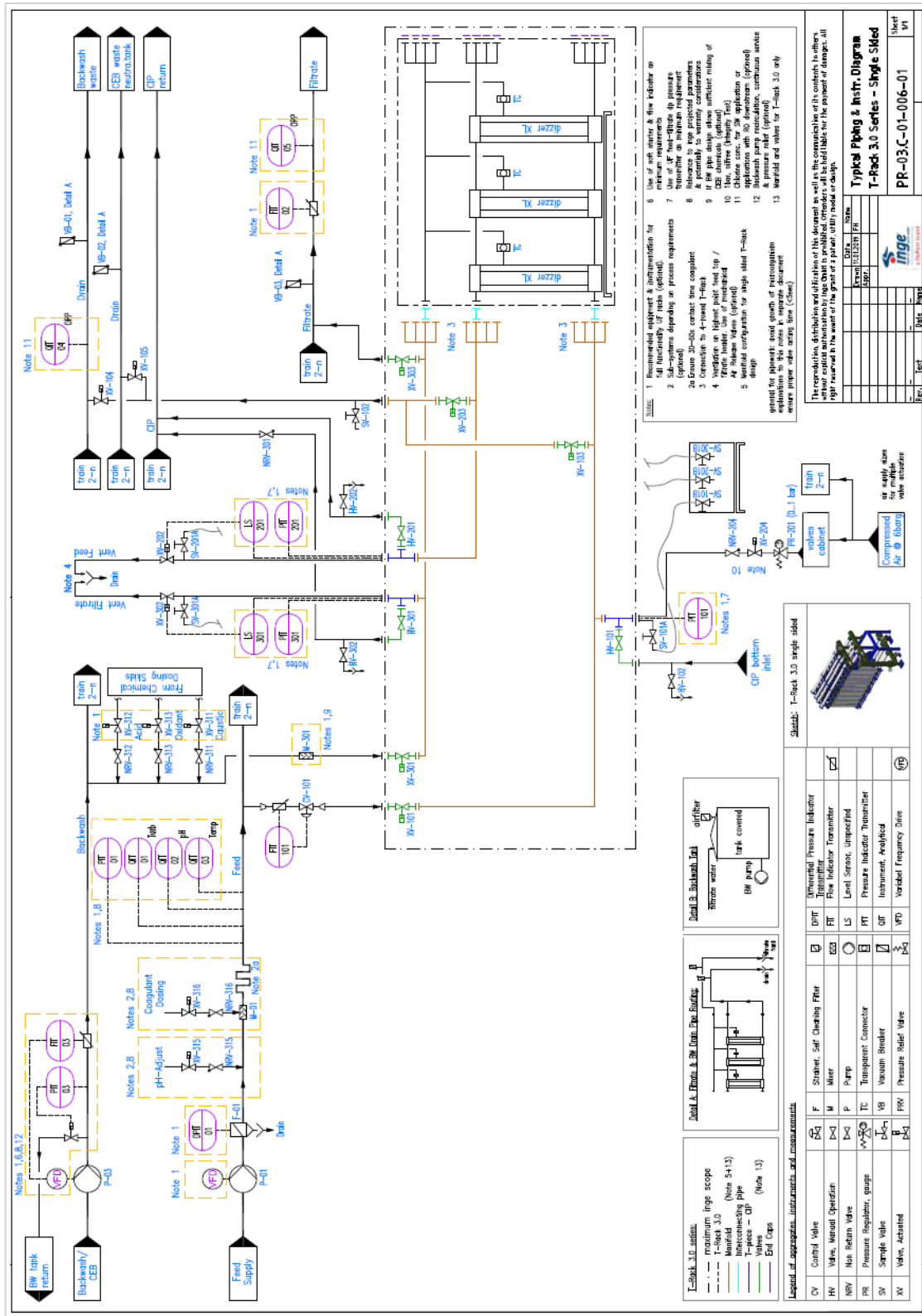

Figure 8.2-2 - Flow Diagram for UF System T-Rack®  
(version single sided)

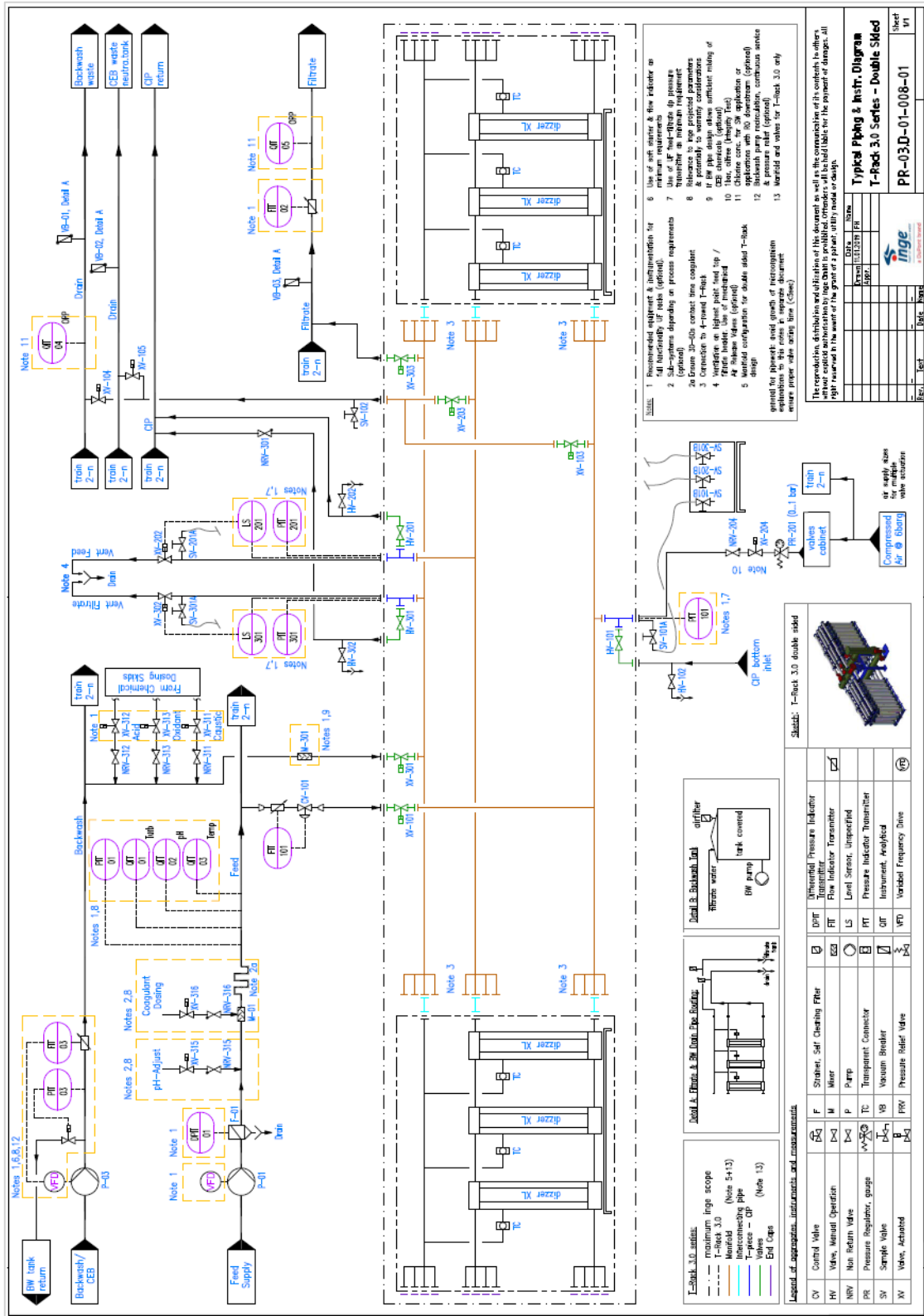

Figure 8.2-3 - Flow Diagram for UF System T-Rack™ (version double sided)

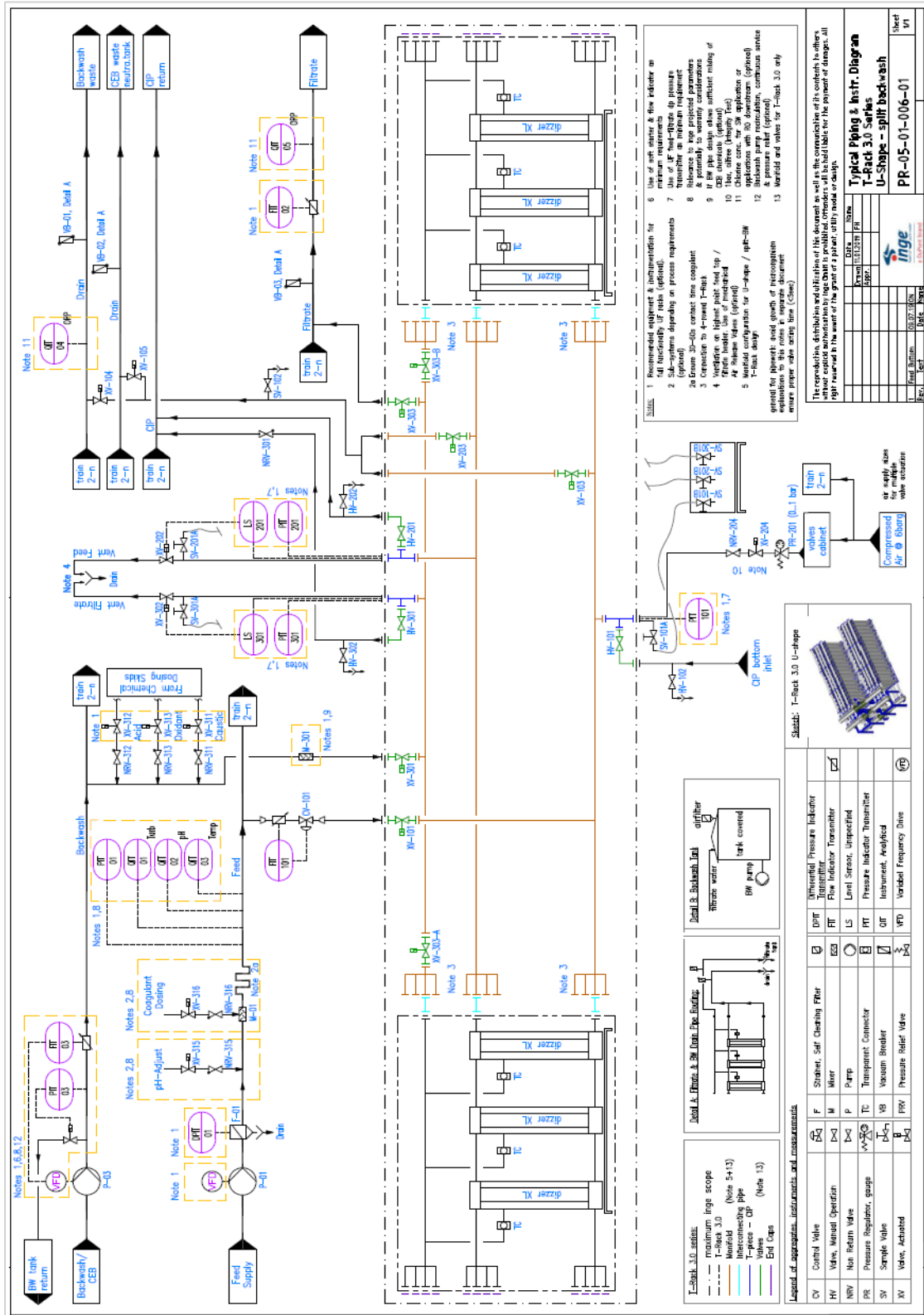



Figure 8.2-4 - Flow Diagram for UF System T-Rack™ (version split rack)

# 10 System Commissioning

## 10.1 General Overview

| <b>NOTE</b>   |  |
|---|--|
|  | <b>ATTENTION!</b><br>Observe the following guidelines! |

- System commissioning comprises functional testing and test operation.
- All PES-UF modules/racks must be put into operation in accordance with the guidelines stipulated below.
- The steps involved in commissioning the system must be logged and archived.
- DuPont™ recommends verifying the composition of the feed water quality before commencing the commissioning process.
- The operating personnel should be incorporated in the commissioning process.
- Before commencing water supply operations, the modules, T-Rack™, filtrate tank(s) and filtrate piping (including all the installed valves, fittings and devices) must be adequately rinsed and then disinfected.
- During system commissioning it is also necessary to determine the chemical injection times for the CEB by measuring the rise in concentration in the rinse water discharged from the rack during chemical dosing.
- Before commencing water supply operations, check that the water produced by the rack(s)/system meets the stipulated requirements.
  - DuPont™ recommends performing integrity tests immediately after the commissioning is completed, as described in the section on "Integrity Testing". This is also an important means of determining the reference value(s) required for future testing. This reference value(s) must be determined and documented during the commissioning process for the fully assembled rack(s).

## 10.2 Functional Testing

| <b>NOTE</b>   |  |
|---|--|
|  | <b>ATTENTION!</b><br>Observe the following guidelines! |

Before beginning test operation, review the SCADA design. Verify that the automatic program control system (programmable logic controller, PLC) is running error-free. Consider checking all items on the below list for completion:

- Verify that all required system instruments are properly assembled and installed.
- Confirm data display, historic data archiving & processing.
- Confirm calculations TMP & permeability (hydrostatic offsets).
- Confirm permeability to be temperature corrected.
- Confirm dry operation all butterfly valves (functionality and adequate opening/closing speed).
- Confirm functionality all vent valves.
- Confirm filtration sequences (Top and Bottom) functional.
- Confirm Backwash Drain Top and Bottom sequence functional.
- Confirm Forward Flush Sequence functional.
- Confirm CEB set points adjustable.
- Confirm correct CEB sequence (caustic – acid – others, if applicable).



### 10.3 Module Preservation

Membranes in the Multibore™ family contain preservative in order to prevent the membranes from drying out, to protect the membranes from freezing temperatures during transport and storage and to inhibit microbiological growth in the membranes. Drying of the pores in the membranes would result in permanent permeability loss due to pore collapse, while freezing of the fluids in the pores could potentially damage the membranes. Microbiological growth wouldn't damage the membranes, but it would necessitate extensive oxidative cleaning.

PES-UF standard preservative solution consists of a mixture of glycerin (1,2,3-propantriol) and propylenglycol (1,2-propanediol). As both glycerin as well as propylenglycol are non-hazardous substances (approved as food additives), and are completely miscible with water, it is relatively easy to rinse these substances out of the modules.

### 10.4 Venting and Rinsing

| <b>NOTE</b>   |   |
|---|---|
|  | <p><b>ATTENTION!</b></p> <p>Observe the following guidelines!</p> |

- After functional testing, but before test operation, the entire system including the piping, connecting pipework must be vented and cleaned to remove any contaminants, abrasive materials and oily substances from the system.
- Before filling the UF system/filtrate tank, it is important to thoroughly clean the filtrate tank to remove any contaminants.
- Ensure that the rinsing process removes the preservation solution from the system. The preservation solution is biologically available when sufficiently diluted with water. Consequently, it is possible that any residue of the preservation solution could cause microbial growth on the filtrate side or in the filtrate tank in certain circumstances.

#### 10.4.1 Venting the System

To vent the module(s) prior to system commissioning, proceed as follows (the various operating modes are described in the section on "Membrane Operating Modes"). Below procedure applicable for each installed UF rack:

1. Filling the feed side with source water
  - Confirm that no valves are closed on the filtrate side.
  - Fill the feed side of the system with source water slowly to avoid water hammer. For this purpose, run the system in filtration bottom (FB) mode at a flux rate of approximately 40 L/(m<sup>2</sup>h) (23.5 GFD) for at least 20 minutes.
  - Where possible, the filtrate should be discharged before it reaches the filtrate tank to prevent the preservation solution from accumulating in the filtrate tank.
2. Venting the modules
  - Run system in forward flush bottom (FFB) mode at a volume flow rate corresponding to a flux rate of approximately 80 L/(m<sup>2</sup>h) (47 GFD) for at least 10 minutes.
3. Filling the filtrate side
  - Confirm that no valves are closed on the filtrate side.
  - Run system in filtration bottom (FB) mode at a flux rate of approximately 40 L/(m<sup>2</sup>h) (23.5 GFD) for at least 15 minutes.

- Run system in filtration top (FT) mode at a flux rate of approximately 40 L/(m<sup>2</sup>h)(23.5 GFD) for at least 15 minutes.
  - Where possible, the filtrate should be discharged before it reaches the filtrate tank to prevent the preservation solution from accumulating in the filtrate tank.
4. In the event that it was not possible to discharge the filtrate before it reached the filtrate tank, empty the filtrate tank completely (including removal of any residue), discharging its contents into the drain, and then clean the filtrate tank if necessary.

## 10.4.2 Rinsing the System

To rinse the system, proceed as follows:

1. Filling the filtrate tank
  - Confirm that no valves are closed on the filtrate side.
  - Run system in filtration bottom (FB) mode at a flux rate of approximately 40 L/(m<sup>2</sup>h) (23.5 GFD) for at least 15 minutes to completely refill the filtrate tank.
2. Performing backwashes
  - Run system in backwash drain top (BWDT) mode for at least 60 seconds (or use up the full volume contained in the filtrate tank).
  - Fill the filtrate tank (see point 1), but this time running the system in filtration top (FT) mode.
  - Run system in backwash drain bottom (BWDB) mode for at least 60 seconds (or use up the full volume contained in the filtrate tank).
  - Fill the filtrate tank (see point 1).

### NOTE



Due to the preservation solution, consisting of glycerin and propylenglycol, some COD will still be measurable after this rinsing procedure. If there are specific limits to the amount of COD in the Wastewater and/or filtered water, then further rinsing might be required. Please contact DuPont™ for further information.

### NOTE



If the modules are used for producing potable water, further rinsing is necessary in order to comply with drinking water regulations. Please contact DuPont™ for further information.

# 11 Disinfecting the System

## NOTE



### ATTENTION!

Observe the following guidelines!

- The chemical sodium hypochlorite (NaOCl) is used to disinfect the system. This chemical is normally supplied as a chlorine bleaching agent in a stock solution containing a concentration of free chlorine of approx. 12-15 wt%.
- If necessary, the disinfection procedure should be performed multiple times.

### Proceed as follows (for each installed UF rack):

1. Add the calculated volume  $V_{\text{dosage}}$  of a NaOCl stock solution to the filtrate tank, which should already be completely filled with filtrate, in order to obtain a concentration of 20mg/l of sodium hypochlorite in the filtrate tank (calculations must be tailored to tank volume). Run a backwash drain top (BWDT) for the furthest installed UF T-Rack™ for at least 30 seconds in order to disinfect the complete filtrate piping. Alternatively, it is also possible to run a chemical enhanced backwash (CEB) bottom to top (with a concentration of 20 mg/l sodium hypochlorite).
2. Run a backwash drain bottom (BWDB) for at least 30 seconds. Alternatively, it is also possible to run a chemical enhanced backwash (CEB) from top to bottom with a concentration of 20 mg/l of sodium hypochlorite.
3. Open and close all the filtrate sampling valves and all other valves in the filtrate piping/filtrate tank area multiple times.
4. Close all the feed valves.
5. Allow the NaOCl to soak for at least 30 minutes (max. 60 minutes).
6. Periodically check the concentration of sodium hypochlorite (at 5-10 minutes intervals). If the level of sodium hypochlorite falls below a value of 5 mg/l, repeat chlorination or add extra doses of fresh stock solution.
7. Run a backwash drain top (BWDT) for at least 60 seconds.
8. Run UF rack in filtration bottom (FB) mode at a flux rate of 80 L/(m<sup>2</sup>h) (47 GFD) for at least 10 minutes.
9. Run a backwash drain top (BWDT) for at least 60 seconds.
10. Run UF rack in filtration top (FT) mode (alt. filtration bottom for single sided operation) at a flux rate of approximately 80 L/(m<sup>2</sup>h) (47 GFD) for at least 10 minutes or until the filtrate tank is completely full.
11. After completion of the disinfection for all installed UF racks, empty the filtrate tank completely (remove any residues right down to the deepest section of the tank).
12. Run all available UF racks in filtration bottom (FB) mode at a flux rate of approximately 80 L/(m<sup>2</sup>h) (47 GFD) for at least 10 minutes.
13. Empty the filtrate tank completely (remove any residues right down to the deepest section of the tank).
14. Run all available UF racks in filtration top (FT) mode (alt. filtration bottom for single sided operation) with the flux rate and filtration time that is envisioned for the subsequent process (i.e. normal operation).
15. Conclude the previous filtration sequence with a regular backwash. The UF system is now ready for operation. Prepare to verify and potentially adjust the BW process, CEB dosing setpoints and timing as well as the UF feed water coagulation procedure.
16. Perform sampling and analysis to check the bacteriological filtrate quality. If the test results are not satisfactory, repeat the disinfection process. Contact DuPont™ if the number of required disinfection processes exceeds a total of six a year.

## 12 Integrity Testing

### 12.1 General Overview

Integrity testing can be an effective means of checking the intactness of the membrane fibers and the modules. Two types of tests are available for PES-UF modules as standard: fully automatic pressure hold test and semi-automatic bubble test with visual inspection.

Both tests are based on the phenomenon seen in wetted ultrafiltration membranes whereby water can pass through the pores, but air is prevented from passing through until a certain pressure has been exceeded (the minimum pressure at which air begins to flow is referred to as the "bubble point"). The bubble point pressure depends on the membrane's pore size and on the surface tension at the air-liquid interface. The bubble point pressure of the pores of PES-UF membranes is much higher than the applied test pressure (approx. 1 bar) that is required to detect non-intact fibers.

As a general rule, integrity testing can be performed on both the feed and filtrate sides. If air is used to displace all the water on one of the two sides of the membrane (feed or filtrate side), the pressure on this side will then continue to increase since the air cannot pass through the wetted pores (this side is referred to in this context as the "high-pressure side"). Once the test pressure has been reached, all the valves are closed on the pressure side. This means that the air can now only escape through defective fibers or epoxy sealing or faulty valves/devices/pipes. A slight pressure drop may be observed due to the natural air diffusion process through the water-filled pores of the membranes. If the pressure differential from the high-pressure side to the low-pressure side is higher than the tolerance limit stipulated by DuPont™ this may indicate a defective fiber or epoxy sealing (or a leakage in the pressurized equipment parts).

In the bubble test, air escaping on the low-pressure side due to defects in the fibers or epoxy sealing is visually confirmed by bubbles appearing in the transparent pipes on the feed or filtrate side (depends on the specific product Series; see Figure 12.4-3). In principle, the bubble test can therefore be performed in conjunction with every pressure hold test.

| <b>NOTE</b>   |   |
|---|---|
|  | <p><b>ATTENTION!</b></p> <p>Observe the following guidelines!</p> |

- In conventional rack systems with PES-UF Modules for Open Platform the test is carried out on the filtrate side, i.e. the high-pressure side in this case is the filtrate side and the transparent pipe is located on the feed side of the module. In T-Rack™ systems the test is carried out on the feed side, i.e. the high-pressure side in this case is the feed side and the transparent pipe is located on the filtrate side of the module.
- Higher test pressures than those recommended by DuPont™ are to be discussed and approved in writing by DuPont™.
- The air used for air integrity testing must comply with at least the air quality specified in 12.2.Compressed Air Specification.  
Using air with lower quality can cause irreversible fouling and is not permitted.

The vertical installation of the modules and the ergonomic configuration of the T-Rack™ system enable pressure hold testing to be carried out automatically, making it easy to detect any affected modules using the bubble test. Integrity testing is carried out on installed modules (i.e. it is not necessary to remove any of the modules from the rack/system).

## 12.2 Compressed Air Specification

### PES-UF Modules for Open Platform and T-Rack™

#### Integrity-Testing & Valve-Cluster

| Application             | Class*<br>[solid.water.oil] | Pressure<br>[barg] / [psi] |
|-------------------------|-----------------------------|----------------------------|
| Cabinet / Valve Cluster | 1.4.2                       | 6.0 / 90                   |
| Integrity test          | 1.4.1                       | 1.0 / 15                   |

| Class | ISO 8573-1 (2010)*   |             |             |      |                               |                         |
|-------|--|-------------|-------------|------|-------------------------------|-------------------------|
|       | solid<br>(particle size and max. concentration [mg/m <sup>3</sup> ]) |             |             |      | water                         | oil                     |
|       | 0.1<d≤0.5µm  | 0.5<d≤1.0µm | 1.0<d≤5.0µm | ppm  | max. pressure dew point (DTP) | mg/m <sup>3</sup> / ppm |
| 1     | ≤ 20 000   | ≤ 400       | ≤ 10        | 0.08 | - 70°C / -94°F                | 0.01 / 0.008            |
| 2     | ≤ 400 000  | ≤ 6 000     | ≤ 100       | 0.8  | - 40°C / -40°F                | 0.1 / 0.8               |
| 3     |  | ≤ 90 000    | ≤ 1 000     | 4.2  | - 20°C / -4°F                 | 1 / 0.83                |
| 4     |  |             | ≤ 10 000    | 6.7  | +3°C / +37°F                  | 5 / 4.2                 |
| 5     |  |             | ≤ 100 000   | 8.3  | +7°C / +45°F                  | 25 / 21                 |

\* according to ISO 8573-1: 2010  
Classification of purity for the particles, water and oil

|                                     |   |                                  |   |   |   |                       |
|-------------------------------------|---|----------------------------------|---|---|---|-----------------------|
| Total air flow rate**<br>@ 1bar     | = | Hold-up volume<br>Module Rack*** | + | Hold-up volume connecting<br>pipework**** | / | Time<br>(recommended) |
| T-Rack™                             | = | feed side                        | + | Feed header / manifold                    | / | 10 minutes            |
| PES-UF Modules for Open<br>Platform | = | filtrate side                    | + | Filtrate header / manifold                | / | 10 minutes            |

\*\* For compressor sizing

\*\*\* Find hold-up volume in the DuPont™ IntegraTec™ P Series | PES In-Out product data sheet

\*\*\*\* To be calculated

## 12.3 Testing Frequency

Both integrity tests (pressure hold and bubble test) should be performed at the end of the commissioning phase, after maintenance work, and in the event of any suspicion that the membrane system may be malfunctioning (e.g. increased bacteria counts on the filtrate side). Integrity testing can also be regularly carried out on an automated basis (for example once a day, once a week or once a month) and seamlessly integrated in standard filtration operations. There are no restrictions on the frequency of integrity testing for PES-UF modules. The frequency can therefore be flexibly tailored to match the regional or operator's specific requirements and preferences.

## 12.4 How to Perform a Pressure Hold Test

A pressure hold test is carried out for each rack in turn, i.e. the modules of a single rack are tested in parallel. The following figure shows an example using the feed side as the high-pressure side.

1. Dewater the respective high-pressure side (feed side for T-Rack™; filtrate side for PES-UF Modules for Open Platform) and build up the pressure:

Fill the entire high-pressure side with dry, oil-free compressed air at a pressure of 1 bar (14.5 psi). The low pressure side of the modules must be left open to drain towards atmospheric pressure. The applied air pressure forces the water through the membrane from the high-pressure side to the low-pressure side (dewatering phase). In principal air cannot pass integral membranes due to the surface tension of the water in the membrane pores (diffusion processes not considered). The duration of emptying a rack depends on total rack size and volume of connected pipework and compressor capacity. Based on experience the dewatering phase takes up to 20 minutes to complete.

2. Once the high-pressure side has been completely emptied of water and a stable pressure of 1 bar (14.5 psi) has been reached (and maintained for at least 1 minute), close the air supply to the high-pressure side.

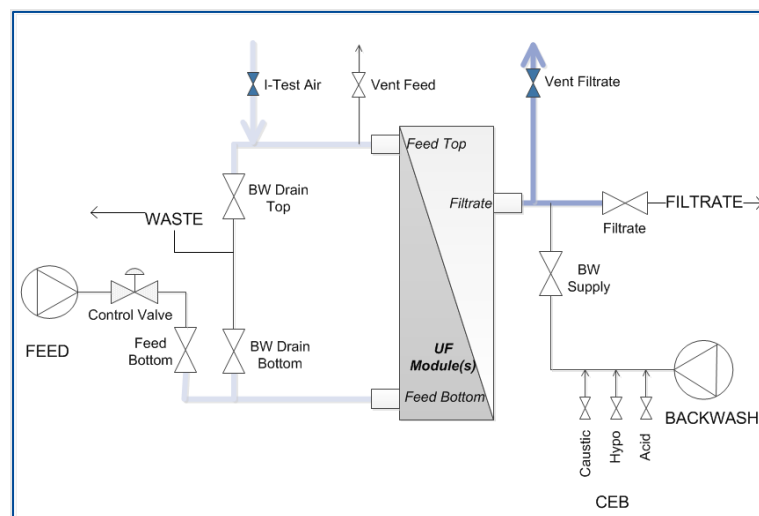

Figure 12.4-1 - Dewatering phase for integrity test from feed side

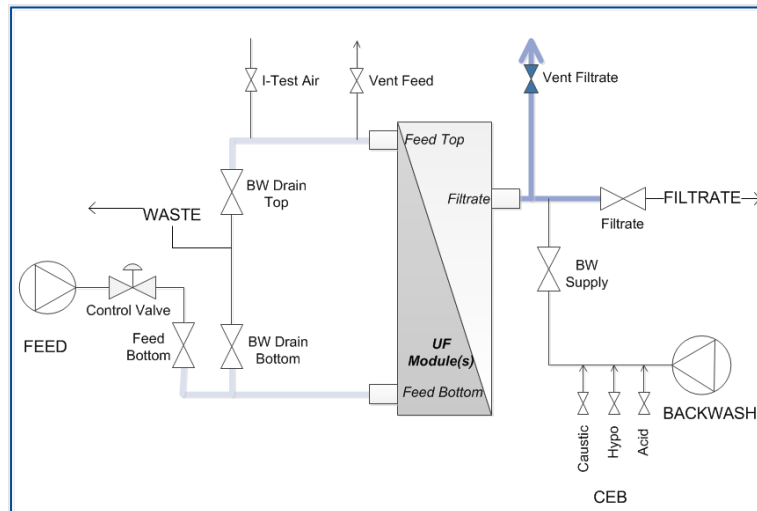



Figure 12.4-2 - Pressure hold phase and pressure measurement for integrity test from feed side

3. Measure the pressure drop:

Measure the pressure drop on the high-pressure side for at least 3 minutes. Due to the air diffusion process through the water-filled pores of the membranes, a slight pressure drop may be observed. This should be taken as a base value and should not be regarded as a membrane leakage due to defective fibers. This diffusion effect may also result in a minor degree of bubble formation becoming visible in the transparent pipe. The base value is dictated by various factors, including the hold-up volume, the tightness of all valves and fittings and the diffusion component of the modules. In the event that the base value is exceeded, we recommend conducting a detailed examination to establish the cause.

| <b>NOTE</b>   |   |
|---|---|
|  | <p><b>ATTENTION!</b></p> <p>Observe the following guidelines!</p> |

- Determination of the base value must be performed using new modules (during system commissioning) in the fully assembled rack. This base value then serves as a reference value. At a test pressure of 1 bar (14.5 psi), this value is expected to be lower than 10 mbar/min for all rack sizes.
- It is important to ensure that the low-pressure side is open, unpressurized and completely filled with water when measuring this value.

4. Bubble test:

Any leakage in an individual module can be detected on the low-pressure side using a built-in transparent pipe (see Figure 11-3). In the event of a leak, a continuous stream of air bubbles of a steady intensity will be visible during the integrity test.

If a significant, uniform stream of air bubbles is visible in the transparent pipe, and if the pressure drop is greater than the base value, it can be assumed that the rack/system has a capillary or epoxy defect, assuming that all other sources of error have been ruled out during the integrity test.



Figure 12.4-3 - Monitoring and ensuring error-free operation of the assembled rack with the help of an integrated transparent pipe on the feed side (in the PES-UF Modules for Open Platform - left) and on the filtrate side (in the T-Rack™ Series - right)

5. Pressure relief:

After performing the pressure hold test, the pressure is released on the high-pressure side. For feed-side tests, this is achieved by opening a valve on the feed/rinse water side, while for filtrate-side tests the pressure is released by opening a valve on the filtrate side.

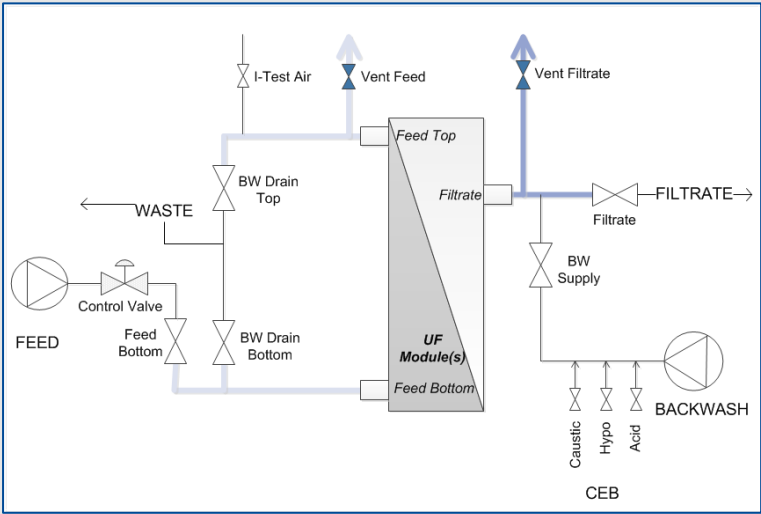

Figure 12.4-4 - Process Flow I-Test Pressure Relief

| <b>NOTE</b> |   |
|-------------|---|
|             | <p><b>ATTENTION!</b></p> <p>Observe the following guidelines!</p> |

- Make sure to carefully control the pressure release, among other reasons to prevent any water/air hammers and any risk to people who may be in the surrounding area.



6. Venting the system:

After completing the integrity test, the rack/system must be vented. Confirm that no valves are closed on the filtrate side.

Run system in forward flush bottom (FFB) mode at a volume flow rate corresponding to a flux rate of approximately 80 L/(m<sup>2</sup>h) (47 GFD) for 5 - 10 minutes.

Regular filtration operation can then resume, starting with a filtration bottom (FB). During the first approx. 5 - 10 minutes, filtration must be performed at a reduced flux rate of approximately 40 L/(m<sup>2</sup>h) (23.5 GFD) to ensure the system is completely vented.

Figure 12.4-5 shows a clear overview of all the steps involved in a pressure hold test on the feed side.

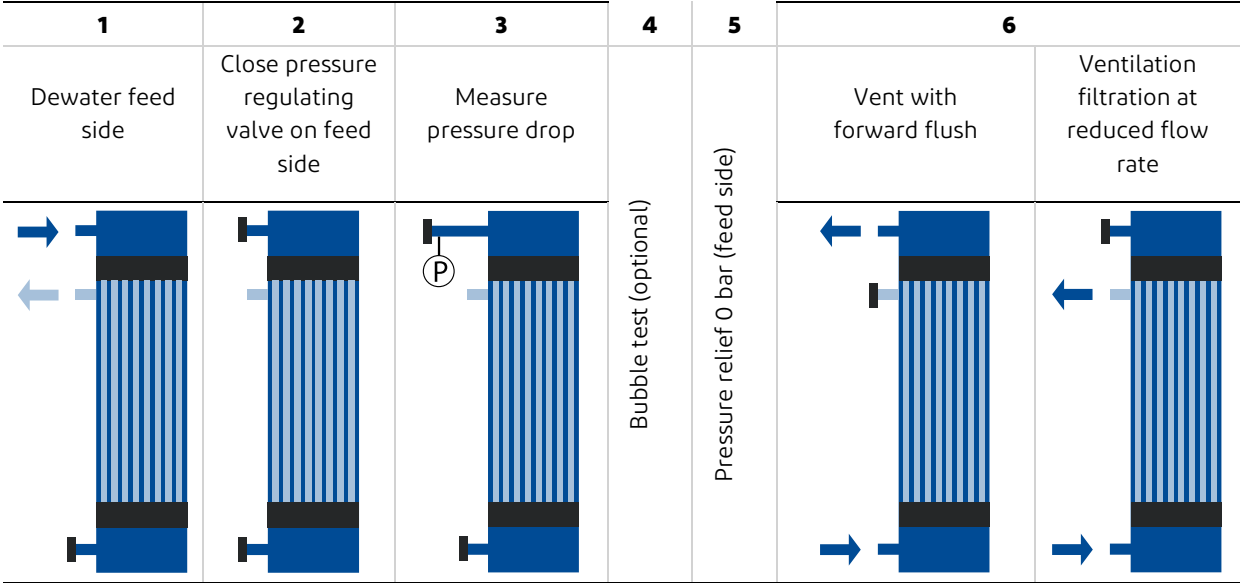



Figure 12.4-5 - Procedure for a feed-side pressure hold test

# 13 Further Operating Guidelines

## 13.1 Avoiding Membrane-Damaging Particles and Substances

Membranes of the Multibore™ family are extraordinarily resistant to chemical, mechanical and thermal damage. Nevertheless, incorrect or improper operation of PES-UF membranes could still potentially cause damage to the membrane material, membrane resin or membrane fibers.

| <b>NOTE</b>   |   |
|---|---|
|  | <p><b>ATTENTION!</b></p> <p>Observe the following guidelines!</p> |

- Any treatment of waters with concentrations of dissolved substances in excess of 7 wt% is a special application which is not covered by the standard terms of the DuPont™ IntegraTec™ warranty policy. We therefore recommend performing pilot testing before building a membrane facility to treat waters of this kind.
- DuPont™ IntegraTec™ warranty policy does not cover modules and membranes that are irreversibly destroyed by particles, substances or foreign objects that are produced within the module/rack or washed into the module/rack by feed water, backwash water, CEB/CIP water or compressed air (for example during integrity testing) due to a failure to comply with DuPont™ IntegraTec™ specific product documentation (including installation manuals and process and design guidelines).
- In particular, the modules' conditions of use prohibit any of the following substances from being introduced into the module(s)/rack(s) on either the filtrate or feed side:
  - Particles and foreign objects > 230 µm for membranes with an inner diameter of 0.7 mm, or maximum 300 for membranes with larger ID.
  - Abrasive, sharp-edged particles that can cause irreversible damage to the membrane surface.
  - Corrosion or erosion products produced in the water treatment plant and washed into the module (e.g. sand or concrete residue from the backwash tank).
  - Foreign objects introduced during installation and maintenance such as metal or plastic shavings.
  - Precipitated material washed into the module during operation (e.g. during a CEB or CIP) or precipitation that forms within the module which has not been properly removed from the module in accordance with the guidelines.
  - Polar, organic or chlorinated solvents.
  - Concentrated acids with a pH < 1 or caustics with a pH > 13.
  - Ozone or any other hydroxyl-radical-producing oxidizing agents from advanced oxidation processes (AOPs) such as UV + H<sub>2</sub>O<sub>2</sub>, UV + TiO<sub>2</sub> or Fenton-like reactions such as H<sub>2</sub>O<sub>2</sub> + Fe(II), Cu(II), Ti(III), Cr(II) or Co(II).

## 13.2 Preventing Chemically Irreversible Fouling

Thanks to their high level of chemical resistance, membranes of the Multibore™ family and modules can be cleaned using a range of chemicals in high concentrations. The standard PES-UF CIP is capable of removing practically all natural water constituents which cannot be removed by regular CEBs and which accumulate in or on the membrane over the course of time.

Nevertheless, failure to operate PES-UF membranes in accordance with the guidelines or the presence of non-membrane-compatible substances in the feed water, backwash water, CEB/CIP water or compressed air could potentially lead to cases of irreversible fouling/scaling which can no longer be removed at a reasonable cost even with the most intensive CIP. Substances of this kind can be found, for example, in blow-down waters from cooling tower water treatment processes, in industrial process Wastewaters and in surface waters containing a significant proportion of Wastewater. We therefore urgently recommend performing pilot testing before building a membrane facility to treat waters of this kind.

| <b>NOTE</b>   |   |
|---|---|
|  | <p><b>ATTENTION!</b></p> <p>Observe the following guidelines!</p> |

- DuPont™ IntegraTec™ warranty policy does not cover modules and membranes that are irreversibly contaminated – to an extent that cannot be successfully rectified even by intensive chemical cleaning – by particles, substances or foreign objects that are produced within the module or washed into the module by feed water, backwash water, CEB/CIP water or compressed air due to a failure to properly comply with DuPont™ IntegraTec™ specific product documentation (including installation manual and process and design guidelines).
- In particular, the modules' conditions of use prohibit any of the following substances from being introduced into the modules/racks on either the filtrate or feed side:
- Organic polymers that are not naturally present in the water being treated. These polymers may not be added to the system either directly upstream from the membrane/module(s)/rack(s) or at any other point in the overall process. These include, for example:
  - Organic coagulants and coagulation aids
  - Organic corrosion inhibitors
  - Organic dispersants
  - Organic wetting agents
- In exceptional cases, the substances listed above may be used or may be present in low concentrations in the water being treated if it has been proven that they do not cause any chemically irreversible fouling. However, this requires prior written approval by DuPont™.

### 13.3 Permitted Conditions of Operation, Rinsing, Cleaning and Disinfection

| <b>NOTE</b>   |   |
|---|---|
|  | <p><b>ATTENTION!</b></p> <p>Observe the following guidelines!</p> |

- All PES-UF modules/casings/racks must be operated and used in accordance with the following operating conditions. Proper compliance with the permitted operating conditions is a prerequisite for making a claim under the warranty.

|                | Maximum system pressure | Maximum rate of pressure change |
|----------------|-------------------------|---------------------------------|
| PES-UF Modules | 5 bar @ 1 °C to 40 °C   | 0,5 bar/s                       |
| T-Rack™        | 5 bar @ 1 °C to 40 °C   | 0,5 bar/s                       |

| <b>Trans-membrane Pressure (TMP)</b> |                           |
|--------------------------------------|---------------------------|
| Filtration:                          | max. 1.5 bar              |
| Backwash:                            | max. 3.0 bar              |
| Integrity test:                      | max. 1.0 bar air pressure |

The permissible transmembrane pressures are not calculated on the basis of membrane strength. Instead, they are designed to ensure stable long-term operation. The burst pressure of the Multibore™ as well as Multibore™ PRO membranes is in excess of 10 bar.

## Permitted Chemicals

Chemicals may only be used in accordance with PES-UF specific product documentation (including installation manuals and process and design guidelines).

|  |           |
|--|-----------|
| Permissible pH range during operation:                                       | pH 3 – 10 |
| Permissible pH range for cleaning:   | pH 1 – 13 |
| Maximum concentration of hydrogen peroxide (H <sub>2</sub> O <sub>2</sub> ): | 500 mg/L  |

The use of sodium hypochlorite is only permitted for the following applications in the maximum concentrations indicated below:

|   |  |  |
|---|--|--|
| <b>Maximum concentration</b>            | For CIP  | 500 mg/L at pH ≥ 9.5   |
|   | For CEB  | 200 mg/L at pH ≥ 9.5   |
|   | At the membrane during continuous dosing             | 0.2 mg/L   |
|   | During shock chlorination at pretreatment stage      | 10 mg/L for 30 minutes, max. once a day  |
|   | Membrane disinfection CEB in Wastewater applications | 10 mg/l for 30 minutes, max. once a week or daily in the event of system shutdown > 24 h < 7 d |
|   | During system disinfection                           | 20 mg/L for 60 minutes, max. 6 times a year  |
| <b>Maximum continuous concentration</b> | In swimming pool applications                        | 0.7 mg/l   |

## Permissible Temperature Ranges

|                                    |              |
|------------------------------------|--------------|
| Maximum temperature range          | 1 °C - 40 °C |
| Maximum rate of temperature change | < 5 °C/ min  |

### NOTE



#### ATTENTION!

Observe the following guidelines!

- Please note that operating the membranes/module(s) with a simultaneous combination of the maximum limits for temperature, pH, effective chemical concentration and/or pressure during all operating modes will have an impact on the membranes' service life.

# 14 System Shutdowns

Please observe the following guidelines for different downtime conditions and durations.

| <b>NOTE</b>   |   |
|---|---|
|  | <p><b>ATTENTION!</b></p> <p>Observe the following guidelines!</p> |

- Membranes/module(s) that have been used must be kept wet at all times.
- To avoid microbial growth during plant shutdowns or storage of decommissioned modules, wet membranes must be rinsed with a suitable disinfectant solution and properly preserved.
- Rinsing prior to a downtime of up to 24 hours. Before a downtime lasting less than 24 hours, a backwash of at least 60 seconds must be performed. No further action is required.
- Rinsing and disinfection for downtimes > 24 hours. For shutdowns >24h, a chlorinated backwash is required prior to shut down. To do so, hypochlorite must be dosed together with caustic soda during backwash to achieve a concentration of 2-3 ppm free chlorine, while operating the caustic soda pump to achieve a pH of 9.0 - 9.5.
- UF racks must be checked daily (feed bottom and filtrate sampling ports) to ensure a residual of a minimum of 0.1 ppm free chlorine. Otherwise the process must be repeated.
- Preserving modules for downtimes > 7 days. Membranes/module(s) must be properly preserved in the event of a system shutdown lasting longer than 7 days. Before taking steps to preserve the membranes/module(s), it is absolutely essential to perform chemical cleaning to remove any organic or inorganic contaminants (fouling, scaling) from the membranes. Please contact DuPont™ for instructions on the preservation method for the PES-UF Modules.

| <b>NOTE</b>   |   |
|---|---|
|  | <p><b>ATTENTION!</b></p> <p>Observe the following guidelines!</p> |

- Whichever of the above situations applies, the membranes/module(s) should be kept hydraulically filled with liquid. The membranes must be kept free of any oxidizing agents during system shutdowns.
- If you wish to use any other disinfectants, please contact DuPont™ beforehand. It is essential to obtain prior written agreement and approval from DuPont™ regarding the chemicals and concentrations that are permitted for use.
- To put the system/module(s)/rack(s) back into operation, it is essential to follow the guidelines for system commissioning.

# 15 Documentation of Operating Conditions

| <b>NOTE</b>   |   |
|---|---|
|  | <p><b>ATTENTION!</b></p> <p>Observe the following guidelines!</p> |

- From the moment the module(s)/rack(s) are first put into operation, the operator is obliged to maintain complete and continuous documentation of the operating parameters and the amount of time the plant has been operated in each of the various operating modes.
- No warranties or warranty claims shall be valid without this documentation.
- The feed water quality must be measured after every chemical dosing procedure and after the pre-filtration stage in front of the UF. The results of the analyses must be documented.

### The following UF system parameters must be recorded and documented:

1. pH value, temperature and turbidity<sup>§</sup> in the feed immediately prior to ultrafiltration (UF)
2. Permeability (@ 20°C), volume flow rate, transmembrane pressure (TMP) and absolute pressure (feed/filtrate) per rack / per filtration line during filtration/backwash, CEB/CIP and integrity testing; realized as a delta p measurement transmitter or with individual transmitters, positioned close to the module(s).

Data shall be automatically collected and logged at least every 2 seconds during backwash and CEB (injection and rinsing) and at least every 3 minutes during filtration and CEB soaking to ensure that all effects of changes in pump operation and/or valve positions (changing modes and procedures) are recorded.

To guarantee adequate documentation and to optimize the membrane plant, the data should be recorded and logged in the shortest possible intervals.

3. Chemicals
  - Use of chemicals for pretreatment, measured directly in the feed prior to ultrafiltration (UF):
    - Type and concentration of coagulants
    - Type and concentration of oxidants
  - Use of chemicals for CEB/CIP, measured within the rack(s) (chemicals in contact with the membranes/module(s)):
    - Type, contact time and concentration of oxidants or other membrane cleaning agents
    - Type, contact time and pH value of acids/bases

The minimum interval for one complete set of measurements (lab or on-line measurements) is one per day or one measurement per CEB/CIP.

In the event of a module defect, it is necessary to provide documentation on the position of the defective module within the rack(s) (line, train/unit, side, position) together with details of the module(s) serial number.

---

§ White light turbidity meters are impacted by dissolved organic molecules while infrared devices are impacted by particles only; therefore, infrared or laser devices are recommended to monitor the UF filtrate turbidity. In addition, glass cuvettes should be replaced on a frequent basis to prevent interferences by scratches.

# 16 Technical Documentation

## 16.1 Other Applicable Documents

- [DuPont™ IntegraTec™ PES-UF In-Out P Series Assembly Manual for T-Rack™](#)  
(Form No. 45-D02230-en)
- [DuPont™ IntegraTec™ PES-UF In-Out P Series Modules for Open Platforms Assembly Manual](#)  
(Form No. 45-D02231-en)

## How to Contact us

Contact us if you need support operating DuPont™ IntegraTec™ P Series-UF systems:

E-Mail: [inge@dupont.com](mailto:inge@dupont.com)

[www.dupontwatersolutions.com/contact-us](http://www.dupontwatersolutions.com/contact-us)

Further information available on our website:

<https://www.dupont.com/brands/integrattec-ultrafiltration.html>



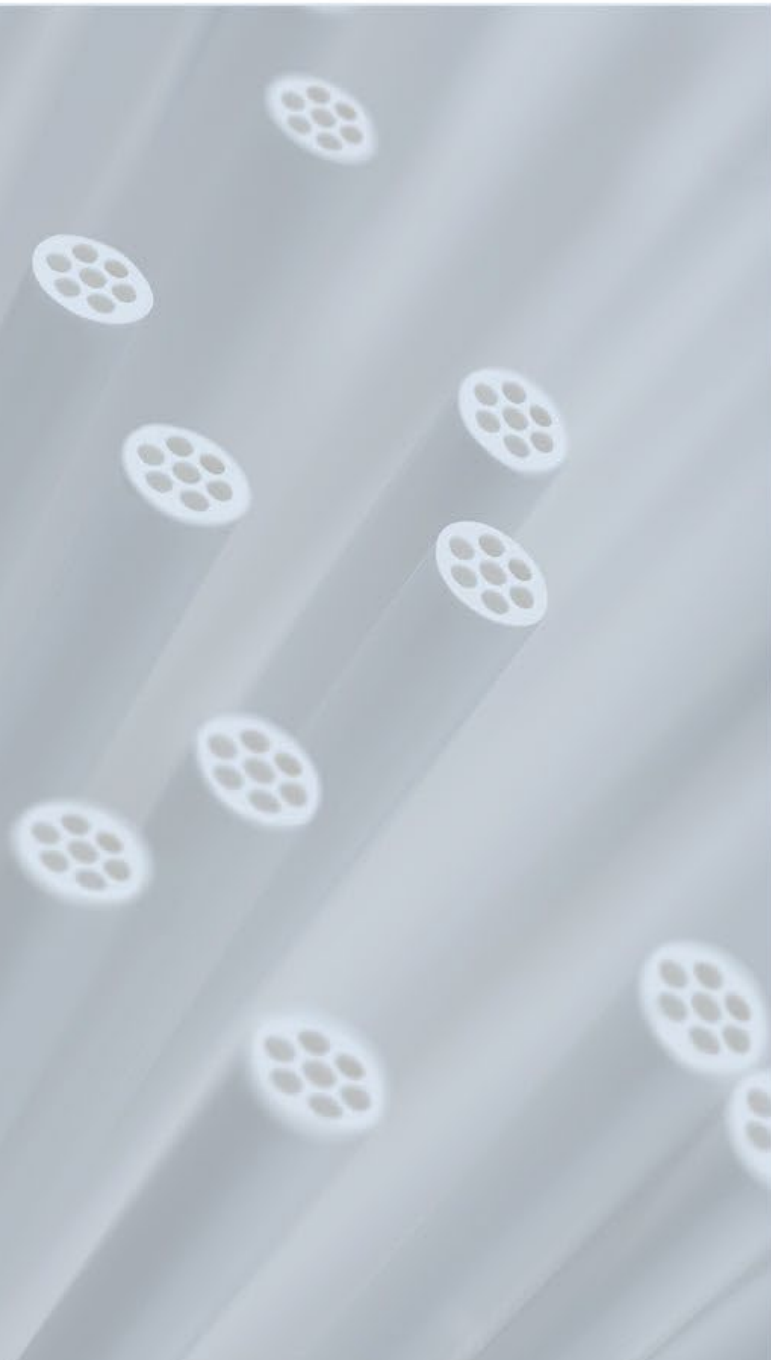
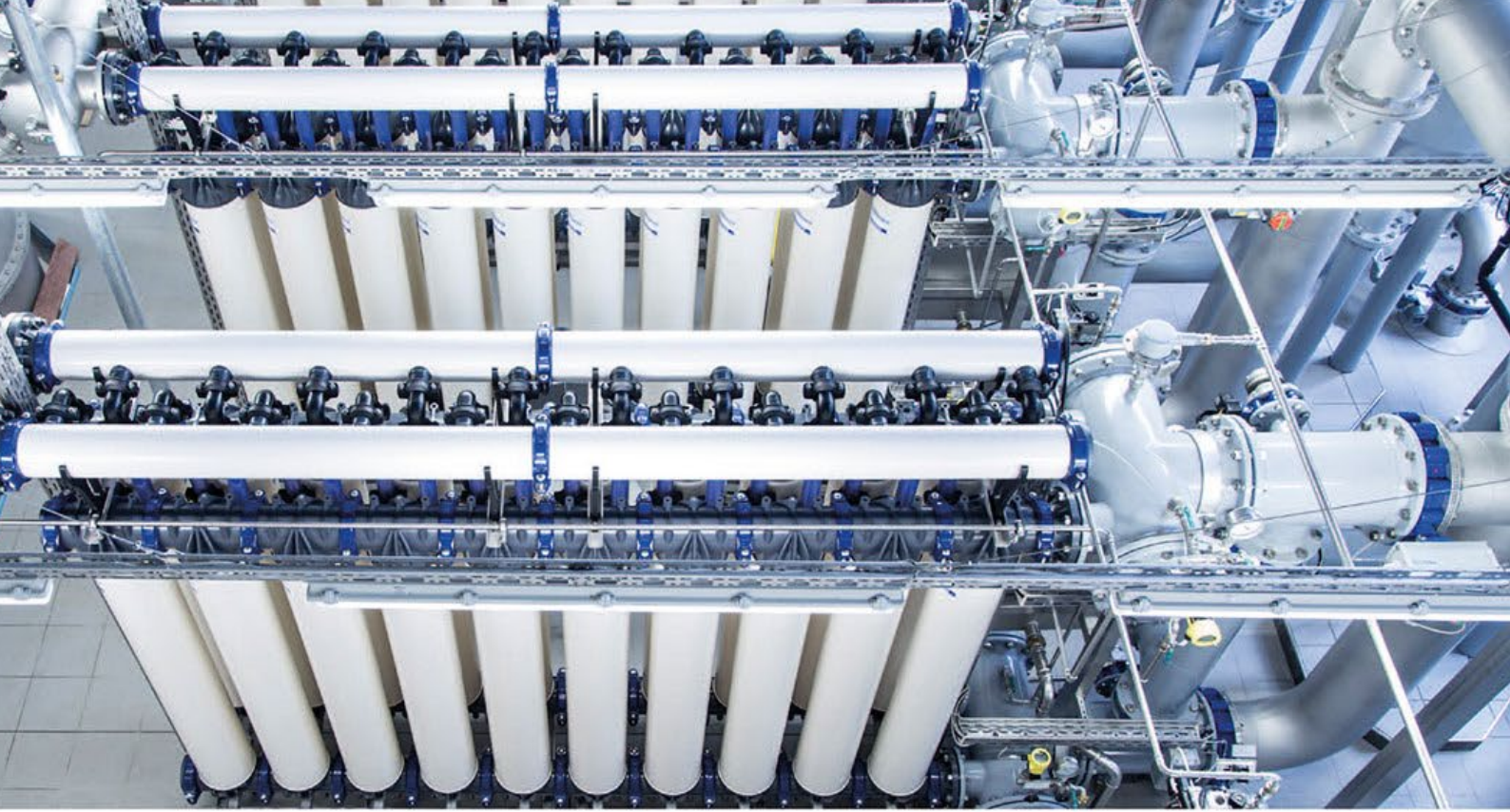

Have a question? Contact us at:

[www.dupont.com/water/contact-us](http://www.dupont.com/water/contact-us)

All information set forth herein is for informational purposes only. This information is general information and may differ from that based on actual conditions. Customer is responsible for determining whether products and the information in this document are appropriate for Customer's use and for ensuring that Customer's workplace and disposal practices are in compliance with applicable laws and other government enactments. The product shown in this literature may not be available for sale and/or available in all geographies where DuPont is represented. The claims made may not have been approved for use in all countries. Please note that physical properties may vary depending on certain conditions and while operating conditions stated in this document are intended to lengthen product lifespan and/or improve product performance, it will ultimately depend on actual circumstances and is in no event a guarantee of achieving any specific results. DuPont assumes no obligation or liability for the information in this document. References to "DuPont" or the "Company" mean the DuPont legal entity selling the products to Customer unless otherwise expressly noted. NO WARRANTIES ARE GIVEN; ALL IMPLIED WARRANTIES OF MERCHANTABILITY OR FITNESS FOR A PARTICULAR PURPOSE

ARE EXPRESSLY EXCLUDED. No freedom from infringement of any patent or trademark owned by DuPont or others is to be inferred.

© 2022 DuPont. DuPont™, the DuPont Oval Logo, and all trademarks and service marks denoted with ™, SM or ® are owned by affiliates of DuPont de Nemours Inc., unless otherwise noted

